



GOLDSCHMIDT

Smart Rail Solutions



GP 210 +S

BATTERY-OPERATED RAIL HEAD GRINDING MACHINE

TRANSLATION OF ORIGIN

Copyright: ©Elektro-Thermit GmbH & Co. KG

All Rights Reserved

This operation manual was produced by Elektro-Thermit GmbH & Co. KG. The applicable copyrights must be observed. Without the prior written approval of Elektro-Thermit GmbH & Co. KG, it is prohibited to reproduce, amend and translate this document, either wholly or in part.

Publisher:

Elektro-Thermit GmbH & Co. KG

Chemiestraße 24

06132 Halle (Saale), Germany

Phone: +49 345 7795-600

Fax: +49 345 7795-770

e-mail: et@goldschmidt.com

Internet: www.goldschmidt.com

Document: manual GP 210 +S
(rail head grinding machine)

Version: 0.0 (translation of origin)

valid from serial number: from GP 210 +S-0001

Build year: from 2025

Country of origin: Deutschland

Trademark use

The names of companies and products used in this operation manual may be registered trademarks of their respective owners.

HISTORY OF CHANGES

Version	Date	Change / Description	Author	Approved by
0.0	2025-03-26	Initial issue	Goldschmidt Holding GmbH	Elektro-Thermit GmbH & Co. KG

STRUCTURE AND CONTENT OF SAFETY INSTRUCTIONS

This operation manual contains safety instructions that point out potential hazards and risks that could result in personal injury, property damage, and/or environmental damage. The way these safety instructions are structured, as well as their contents, is based on the ANSI Z535 standard.

Safety instructions related to personal injury



DANGER indicates a hazardous situation that, if not avoided, will result in death or serious injury.



WARNING indicates a hazardous situation that, if not avoided, could result in death or serious injury.



CAUTION indicates a hazardous situation that, if not avoided, could result in minor or moderate injury.

The contents of all safety instructions related to personal injury have been structured in conformity with the German SAFE method:

SIGNAL WORD/ SYMBOL

S – Schlagwort (keyword)

A - Art und Quelle der Gefahr (type and source of hazard)

F - Folgen bei Nichtbeachtung (consequence of failure to observe the instruction)

E - Entkommen (how to avoid the hazard)

Safety instructions related to property damage and the environment



NOTICE (white text on a blue background) indicates potential property damage.



NOTICE (black text on a green background) indicates potential environmental damage.

General notes



NOTICE (black text on a white background) indicates general information that needs to be taken into account when handling the product.

This operation manual has safety instructions at various points in order to ensure that meaningful information is provided in regard to potential hazard sources:

- Introductory safety instructions (at the beginning of the document)
- Section-specific safety instructions (at the beginning of a section)
- Embedded safety instructions (for specific instructions).

SAFETY INSTRUCTIONS

Safety instructions related to personal injury



RISK OF INJURY.

Working under the influence of drugs and/or alcohol will result in serious injury.

Consuming drugs and/or alcohol in the work area is strictly prohibited.

Operators under the influence of drugs and/or alcohol are strictly prohibited from operating the equipment.



RISK OF INJURY.

Unforeseeable operating conditions may occur if any of the guards or safety devices on the rail head grinding machine are faulty or removed. Personal injury and property damage may occur.

- Before working with the machine, make sure to familiarize yourself with the entire operation manual.
- Do not, under any circumstance, operate the machine if it is not in proper working condition! Make sure to always observe all instructions in this operation manual.
- Follow all safety instructions without fail!



RISK OF INJURY.

Flying sparks pose a risk of injury to operators and other people in the vicinity. Highly flammable objects may ignite.

- Wear flame-resistant clothes when working.
- Wear appropriate eye protection.
- Remove any highly flammable objects from the vicinity.



RISK OF INJURY.

There is a risk of injury due to fire and/or explosion.

Damaged batteries and incorrectly handled batteries may behave in an unforeseeable manner, which can result in a fire or explosion and the associated risk of injury.

- Do not, under any circumstance, use any damaged or modified batteries!
- Properly dispose of all damaged batteries!
- Do not expose the batteries to fire or extreme temperatures!
- Follow all charging instructions and make sure to never charge the batteries outside of the temperature range specified in the manual provided by EGO (please refer to the EGO operation manual, Chapter 1.4 "Further applicable documents" on page 4).

**RISK OF INJURY.**

There is a risk of injury posed by repairs that are not carried out correctly.

Repairs to the rail head grinding machine must be carried out exclusively by Elektro-Thermit GmbH & Co. KG or specially trained personnel.

- Work on electrical system components must be carried out exclusively by qualified electricians.
- Parts and components must be replaced exclusively with identical spare parts. When replacing a component, make absolutely sure to observe all the component manufacturer's instructions and specifications.

**HOT SURFACES.**

Hot surfaces pose a burn hazard.

The surfaces of the grinding wheel and/or the rail may be hot after grinding and result in burns or other irreversible injuries if touched.

- Make sure to always wear all necessary personal protection equipment (especially work gloves).
- Let the components cool down first before changing the grinding wheel or carrying out maintenance work.
- Let the rail cool down after welding (below 40 °C / 104 °F).

**RISK OF INJURY.**

Unauthorized access poses a risk of injury.

Whenever you are not operating the rail head grinding machine, make sure that it cannot be turned on by accident.

Remove all batteries from the rail head grinding machine when not operating it.

**HEARING LOSS.**

Noise levels during grinding may result in permanent hearing loss.

Make sure to always wear hearing protection.

Individuals who are not working with or on the grinding machine must stay at a minimum distance of 1.5 m / 59 inches.

Agree on clear and effective hand signals for communication.

**RISK OF INJURY.**

Incorrectly operating the rail head grinding machine poses a risk of injury.

This operation manual must be accessible to operating and maintenance personnel at all times!

Before any work is carried out with the rail head grinding machine, the corresponding individuals must have read, understood, and observed this operation manual!

**RISK OF INJURY.**

Poor weather conditions (rain, snow) pose a risk of injury due to poor visibility or slippery surfaces.

- Stop all work if the surfaces you will be standing on are slippery.
- Stop all work if visibility is poor.

**CAUTION****RISK OF INJURY.**

There is a risk of injury due to abnormal vibrations.
If you notice any abnormal vibrations while working with the rail head grinding machine, stop operating the machine immediately.

- Start troubleshooting (please refer to Chapter 6 "Fault, Cause and Elimination" on page 32).
- Turn the rail head grinding machine off until the cause of the vibrations has been found and fixed.
- Check to make sure that the grinding wheel is properly mounted on the spindle and adjust it if necessary (please refer to Chapter 7 "Maintenance and Care" on page 37).

**CAUTION****RISK OF INJURY.**

There is a risk of injury due to failure to pay attention, as well as due to signs of mental fatigue that increase the risk of personal injury and property damage.

- Always observe all legally required breaks.
- Do not, under any circumstance, work alone. Make sure to rotate the task on a regular basis if possible.

**CAUTION****RISK OF INJURY.**

There is a risk of injury posed by the machine's weight.
Physically demanding work can harm your body in the medium and long terms.

- Always observe all legally required breaks.
- Do not, under any circumstance, work alone. Make sure to rotate the task on a regular basis if possible.

**CAUTION****RISK OF INJURY.**

There is a risk of injury posed by the machine's weight.
The rail head grinding machine weighs 40 kg / 88.18 lbs without grinding wheel and batteries. There is a risk of injury when the machine is being transported.

- Carrying the rail head grinding machine is mandated as a two-person job.
- Use the handles to carry the rail head grinding machine.
- Always wear safety footwear.

**CAUTION****RISK OF INJURY.**

There is a risk of injury posed by hazards from the rail head grinding machine's surroundings.

- Please note that it is impossible for this operation manual to determine and list all the hazards that may be posed by the rail head grinding machine's surroundings and by unforeseeable operating conditions.
- Do not make any alterations to the rail head grinding machine that could result in a change to the way it works.

**RISK OF INJURY.**

Failure to pay attention and mental or physical fatigue will increase the risk of personal injury and property damage.

- Always observe all legally required breaks.
- Do not, under any circumstance, work alone. Make sure to rotate the task on a regular basis if possible.

Safety instructions related to property damage

NOTICE

Make sure that there are no highly flammable or explosive substances in the vicinity. If necessary, remove any combustible substances from the work area and ensure that there is adequate ventilation.

NOTICE

Do not place the rail head grinding machine in water or hose it down.

NOTICE

Genuine spare parts and/or accessories authorized by the manufacturer help ensure safety.

Using any other accessories will void our liability for resulting damages.

The manufacturer hereby disclaims all liability for any components retrofitted by the operating company.

NOTICE

Alterations, repairs, and modifications require the manufacturer's explicit approval.

NOTICE

Make sure to keep all safety labels in legible condition! If safety labels are damaged or go missing at any point in the machine's service life, the operating company must ensure that they are replaced properly.

NOTICE

The manual GP 210 +S must be read carefully before starting any operation, assembly, installation, and/or maintenance work!

NOTICE

A hard copy of the manual GP 210 +S must be available in legible condition at the location of use.

NOTICE

In addition to the information and instructions in this operation manual, all applicable accident prevention regulations and environmental and occupational health and safety regulations must be complied with. Moreover, all of the operating company's accident prevention rules and policies must be followed.

All safety requirements set forth by the applicable rail authorities for work on tracks and in the vicinity of tracks must be followed without fail.

Safety instructions related to the environment

Environmentally hazardous substances must be properly disposed of in compliance with all applicable requirements and regulations. Make sure to observe the manufacturer's data sheets and safety data sheets. For more detailed information, please refer to Chapter 9 "Disposal" on page 58.

NOTICE

Properly dispose of all packaging material. For more detailed information, please refer to Chapter 9 "Disposal" on page 58.

RESIDUAL RISK WARNING

All the components in the battery-operated rail head grinding machine GP 210 +S have been designed in line with the state of the art. Regardless of this, however, their use may pose hazards to the operator and to third parties, the environment, and/or other equipment. Accordingly, the battery-operated rail head grinding machine GP 210 +S must be used only when it is in proper working condition. Moreover, it must always be used in conformity with all applicable safety rules and regulations and the manual GP 210 +S.

Risk of workplace injury

Welding and grinding work both take place in work environments where it is possible for welding and other work to be in progress at the same time and in the immediate area. Accordingly, there is a higher risk of injury due to scenarios including, but not limited to:

- Rail traffic on adjacent tracks,
- Being struck or run over by construction vehicles,
- Getting caught or entrapped in construction vehicles or other moving machinery,
- Slipping on slippery, wet, or oily surfaces,
- Tripping on obstacles,
- Falling onto pointed or sharp objects and
- Burns due to hot surfaces.

Make sure to take the following precautions:

- Observe all work site rules,
- Make sure that there is nobody else within the machine's danger zone,
- Make sure to work only if there is adequate lighting,
- Be careful and alert at all times,
- Make sure that there is adequate ventilation and
- Do not, under any circumstance, leave the running drive unit unsupervised.

ABBREVIATIONS



Units of measurement	
%	Percent
°C	Degrees Celcius
°F	Degrees Fahrenheit
Ah	Ampere-hour
dB (A)	Decibels at a specific measuring distance
HP	Metric horsepower (1 HP = 0.735 kW)
in	inch
kg	Kilogram
kW	Kilowatts
L	Liter
L/min	Liters per minute
lbs	Pounds
mm	Millimeters
rpm	Revolutions per minute
V	Volts

General	
e.g.	for example
max	maximum
min	minimum

GLOSSARY

Symbols and pictograms

Symbol	Explanation
	Warning: hot surface
	Mandatory action: wear protective clothing
	Mandatory action: wear safety footwear
	Mandatory action: wear work gloves
	Mandatory action: wear eye and hearing protection
	Mandatory action: wear a mask

Symbol	Explanation
 A black and white pictogram within a square border. It depicts a hand on the left side, with its fingers being crushed by two interlocking gears on the right side. The gears are positioned such that they appear to be moving towards the hand.	Pictogram: crush hazard posed by moving parts
 A black and white pictogram within a square border. It shows a stylized human figure from the side, holding an open book in front of them and looking down at it, representing the action of reading.	Pictogram: read and follow the operation manual

CONTENT

History of Changes.....	iii
Structure and content of safety instructions.....	iv
Safety Instructions.....	v
Residual Risk Warning.....	x
Abbreviations.....	xi
Glossary.....	xii
CHAPTER 1: INTRODUCTION	
1.1 Information about this document.....	1
1.2 Validity.....	1
1.3 Requirements for operators.....	1
1.3.1 Skills.....	1
1.3.2 Qualification levels.....	2
1.3.3 Personal protection equipment.....	3
1.4 Further applicable documents.....	4
1.5 Scope of delivery.....	5
CHAPTER 2: CONSTRUCTION DESCRIPTION	
2.1 Function description.....	6
2.2 Intended use.....	6
2.3 Operating conditions.....	7
2.4 Main sub-assemblies.....	7
2.4.1 Rating plate.....	8
2.5 Operator control and display elements.....	9
2.5.1 LED display.....	9
2.5.2 Key switch.....	10
2.5.3 Control lever.....	11
2.6 Colors and safety labels.....	12
2.6.1 Coloring.....	12
2.6.2 Safety labels.....	12
2.7 Safety systems.....	14
2.8 Fire extinguisher.....	15
2.9 What to do in case of emergency.....	15
2.10 Accessory devices.....	16
2.10.1 Rechargeable battery.....	16
2.10.2 Charger.....	18
CHAPTER 3: COMMISSIONING	
3.1 Functional test.....	20
CHAPTER 4: OPERATION	
4.1 Inserting the batteries.....	22
4.2 Grinding.....	24
4.3 Adjusting the speed.....	27
4.4 Removing the batteries.....	28
CHAPTER 5: DECOMMISSIONING (SHUTDOWN)	
CHAPTER 6: FAULT, CAUSE AND ELIMINATION	
6.1 Error codes on the LED display.....	34

CHAPTER 7: MAINTENANCE AND CARE

7.1	Maintenance schedule	39
7.2	Visual inspection of the GP 210 +S.....	39
7.3	Visual inspection and condition check Safety labels and rating plate	40
7.4	Cleaning the GP 210 +S	41
7.5	Cleaning the air filter.....	42
7.6	Changing the air filter.....	45
7.7	Changing the grinding wheel	48
7.8	Checking the screw connections to make sure they are secure	52

CHAPTER 8: TRANSPORTATION AND STORAGE

8.1	Transport of the GP 210 +S	54
8.2	Storing the GP 210 +S.....	55
8.3	Putting the GP 210 +S back into operation.....	56

CHAPTER 9: DISPOSAL**CHAPTER 10: CUSTOMER SERVICE**

10.1	Contact details	59
	Annex A - Technical Data.....	I
	Annex B - General Drawings	III
	Annex C - Declaration of Conformity.....	IV
	Annex D - Accessories.....	V
	List of Figures.....	VI
	List of Tables.....	VII
	Index	VIII

1 INTRODUCTION

Summary

This section provides information regarding the scope and content of this operation manual, as well as references to additional documents.

1.1 Information about this document

This operation manual describes how the battery-operated rail head grinding machine GP 210+S works and its components.

This operation manual must be:

- Considered part of the product,
- Stored safely throughout the product's entire service life and
- Passed on to any subsequent users.

1.2 Validity

This operation manual (version 0.0 (translation of origin)) is meant for the following machine configuration:

- battery-operated rail head grinding machine GP 210 +S from serial number GP 210 +S-0001

1.3 Requirements for operators

The operators who will be using the battery-operated rail head grinding machine GP 210+S must:

- Be at least 18 years old,
- Have the required qualifications for the job,
- Have received training regarding how to operate the machine properly and
- Have passed a medical assessment of fitness for work.

NOTICE

All applicable accident prevention regulations must be complied with without fail. Moreover, all operation and maintenance manuals must be followed without exception.

NOTICE

The operating company must make sure that its operating personnel has fully understood the manual GP 210 +S's contents.

1.3.1 Skills

Only individuals who meet the following requirements are allowed to work with and on the machine:

- Operators must have read and understood this operation manual in its entirety.

- Operators must be in perfect health and in full possession of their mental and physical faculties.
- Operators must be rested and must not be under the influence of any drugs, alcohol, or medications that could have a negative impact on their ability to react to situations and absorb information.
- Operators must be regularly briefed on impediments, hazards, fire safety rules, and special rules regarding what to do and what not to do.
- Operators must wear all required personal protection equipment in order to ensure that all occupational health and safety requirements are met.
- Operators must always observe their employer's rules and policies regarding safety and accident prevention and comply with all regulations that are relevant to personal safety and the safety of third parties.

1.3.2 Qualification levels

In order to ensure that the machine will be operated safely and as intended, two different qualification levels must be considered:

- Operating personnel:

Is trained on how to regularly operate the machine, receives continuous training regarding technical innovations, and has the required basic skills and understanding needed to work with the battery-operated rail head grinding machine GP 210+S.

During their initial training session, operators must receive training regarding the following main points:

- Function description,
 - An explanation of the individual components,
 - An explanation of potential hazards,
 - How to use the machine and
 - How to identify malfunctions and other issues.
- Maintenance personnel/specialized personnel:

Personnel that has received special training and briefing intended specifically for maintenance, servicing, and/or repair work on the machine.

Table 1-1 on page 3 lists the various individual tasks that apply to each of the two qualification levels.



Tab. 1-1 Qualification level

Occupation	Qualification level	
	Operating personnel	Maintenance/specialized personnel
Working with the machine, operating the machine	x	x
Cleaning the machine	x	x
Visual inspection	x	x
Identifying malfunctions and other issues	x	x
Maintenance work		x
Troubleshooting and repairs		x



1.3.3 Personal protection equipment

Provided that the operating company does not set forth any additional rules, policies, or guidelines, the following protection equipment must be worn when working with or on the machine:

Tab. 1-2 Personal protection equipment

Symbol	Protection equipment	Use
	Wear protective clothing Welding clothing in conformity with EN 470-1; if necessary, high-visibility clothing in conformity with EN 471	<ul style="list-style-type: none"> • Transport, • Commissioning, • Operation, • Decommissioning, • Maintenance and • Cleaning and maintenance.
	Wear safety footwear (high-top S3 safety footwear in conformity with EN ISO 20345)	
	Wear work gloves (heavy-duty gloves in conformity with EN 388 (4242), EN 402; if necessary, heat-resistant work gloves in conformity with EN 407)	

Tab. 1-2 Personal protection equipment <continuation>

Symbol	Protection equipment	Use
	Mandatory action: wear eye and hearing protection	- Operation (grinding)
	Wear a mask	

1.4 Further applicable documents

NOTICE

Passing the manual GP 210 +S on to third parties requires written consent from Elektro-Thermit GmbH & Co. KG.

NOTICE

The manufacturer's technical documentation is protected by copyright.

NOTICE

In addition to the information and instructions in this operation manual, all applicable accident prevention regulations and environmental regulations must be complied with. Compliance is also required with the safety regulations issued by the railway authorities for working on and near the tracks.

Additional applicable documents are listed in the tables below and are an integral part of the included contents:

Tab. 1-3 Additional applicable documents – supplier documentation

Technical documentation (supplier documentation)
Operation manual EGO Power+ 56V-ARC-Lithium™ Rechargeable battery [made by EGO] and battery charger "700 W RAPID+ charger CH7000E"

Tab. 1-4 Additional applicable documents – manufacturer documentation

Technical documentation (manufacturer documentation)
Work instructions for the relevant Thermit® welding process

1.5 Scope of delivery

NOTICE

The EGO Power+ 56V-ARC-Lithium™ batteries and the charger are not included.

The included contents, as defined contractually, are listed in the following table (please refer to Table 1-5 on page 5):

Tab. 1-5 Scope of delivery

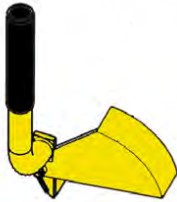
Quantity	Designation	Figure
1	battery-operated rail head grinding machine GP 210 +S	
1	stone wrench (tool for loosening the grinding wheel)	

2 CONSTRUCTION DESCRIPTION

Summary

An overview of the battery-operated rail head grinding machine GP 210 +S, the names of the various sub-assemblies and components, and what they do.

NOTICE

Unauthorized alterations are impermissible.
The manufacturer hereby disclaims all liability for any resulting personal injury and/or damages to machinery and other property.

NOTICE

The manufacturer hereby disclaims all liability for any improper or unintended use and any resulting injury and/or damages.

NOTICE

Any other use of the GP 210 +S, including any use that extends beyond the intended use, is impermissible.

2.1 Function description

The battery-operated rail head grinding machine GP 210 +S can be used to remove protruding welds or rust from a rail head.

The battery-operated rail head grinding machine GP 210 +S is an electric machine that is powered with two EGO Power+ 56V-ARC-Lithium™ rechargeable batteries. These batteries feature a charge status indicator.

The battery-operated rail head grinding machine GP 210 +S is meant to be used with a grinding wheel that measures 6" (15.24 cm) in diameter, 3" (7.62 cm) in thickness, and with a 5/8"-11 UNC arbor hole.

In addition, the grinding wheels must be suitable for use at speeds of up to 3400 revolutions per minute.

For better ergonomics, the handlebar is height-adjustable.

The rail head grinding machine motor is switched on using the Key switch. Speed can be controlled in a continuously variable manner using the Control lever.

In addition, the battery-operated rail head grinding machine GP 210 +S features an LED display that provides an overview of the machine's status with various indicators.

2.2 Intended use

The battery-operated rail head grinding machine GP 210 +S is intended to be used to remove excess material from the rail head.

The battery-operated rail head grinding machine GP 210 +S is an electric machine that is powered with two EGO Power+ 56V-ARC-Lithium™ rechargeable batteries.

The battery-operated rail head grinding machine GP 210 +S is meant to be used with a grinding wheel that measures 6" (15.24 cm) in diameter, 3" (7.62 cm) in thickness, and with a 5/8"-11 UNC arbor hole.

Intended use also extends to:

- Reading and observing the operation manual,
- Observing all maintenance intervals,
- Complying with all applicable occupational health and safety and accident prevention regulations throughout the machine's entire lifecycle and
- Exclusively using operators who have the required technical training, and authorization from the operating company, to be able to carry out work with and/or on the machine.

2.3 Operating conditions

NOTICE	Do not, under any circumstance, operate the machine if actual conditions differ from these operating conditions.
NOTICE	Before putting the machine into operation, always check to make sure that all operating conditions are met.
NOTICE	If the batteries have gotten too cold (e.g., overnight), let the machine run idle for a few minutes so that the batteries will be able to reach their operating temperature. Running the motor under load while the batteries are too cold will shorten their life substantially.

Table 2-1 on page 7 describes the operating conditions in greater detail:

Tab. 2-1 Operating conditions GP 210 +S

Operating conditions	
Ambient temperature when operating the machine	-20 °C to +40 °C (-4 °F to +104 °F)
Ambient temperature when charging the batteries	+5 °C to +40°C (+41 °F to +104 °F)

The following conditions must be met while the machine is being operated:

- It is strictly prohibited to defeat or otherwise disable guards, safety devices, and other components.
- Do not operate the machine if it is not in proper working condition.
- All inspection and maintenance intervals must be observed.
- Do not operate the machine in hazardous locations or in the vicinity of flammable or explosive liquids or gases.
- The work area must be adequately lighted in order to make it possible to identify potential hazards in a timely manner.
- Only ever operate the machine in dry locations.
- Do not operate the machine on gradients of 10° or more.

2.4 Main sub-assemblies

Figure 2-1 on page 8 shows the main sub-assemblies on the battery-powered rail head grinding machine GP 210 +S.

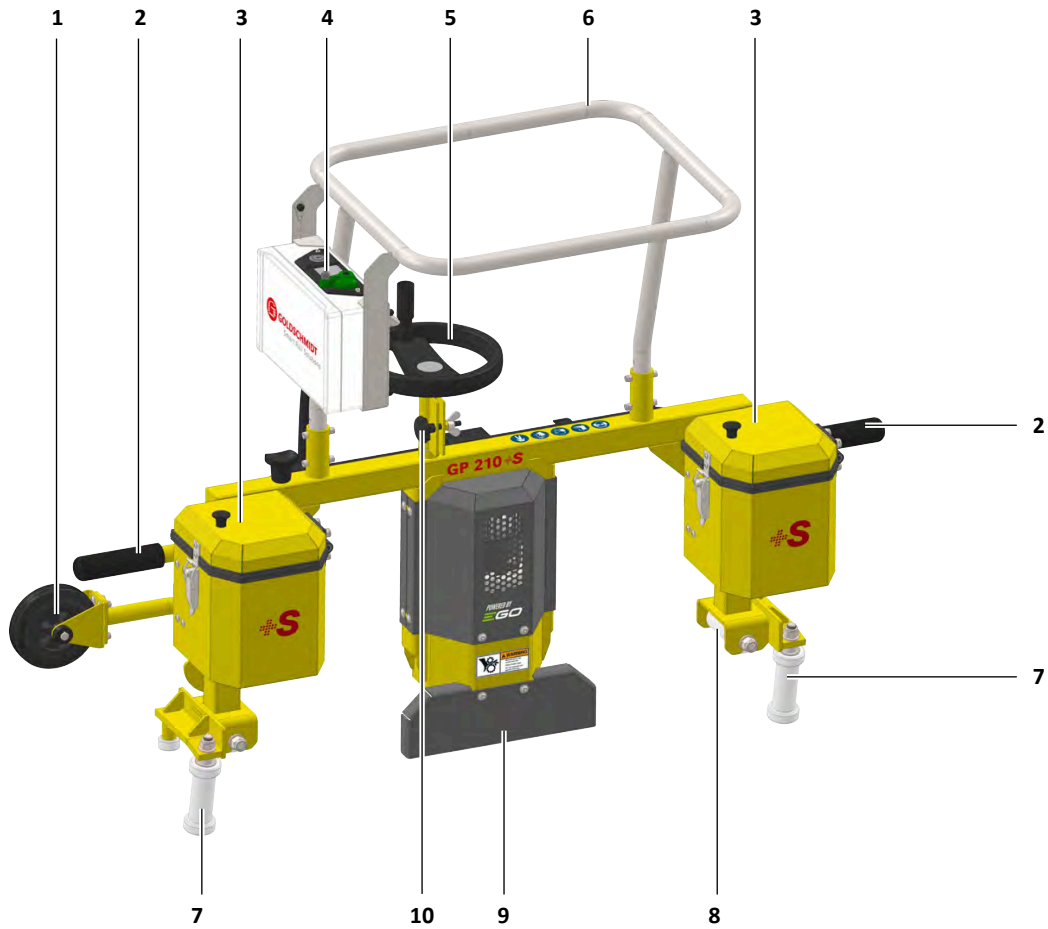

Fig. 2-1 Main sub-assemblies GP 210 +S

1	Transport wheel	5	Handwheel	9	Guard
2	Carrying handle	6	Handlebar	10	Star knob screw
3	Battery compartment	7	Guide roller		
4	Control unit with LED display	8	Rail roller		

2.4.1 Rating plate

Figure 2-2 on page 9 shows the rating plate of the battery-operated rail head grinding machine GP 210 +S.

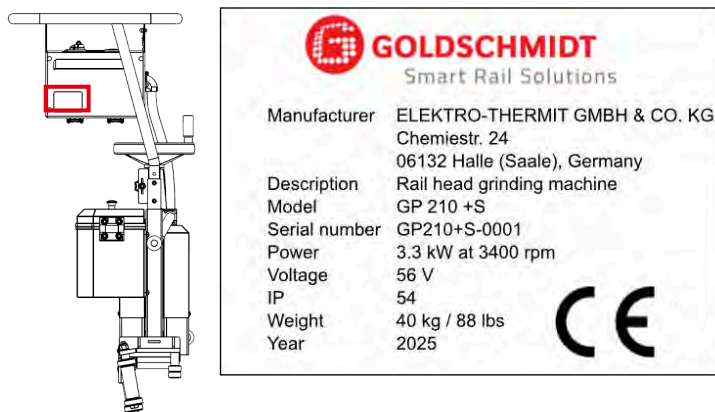

Fig. 2-2 Rating plate

The rating plate includes the following information:

- Manufacturer information,
- Product model,
- Year of manufacture,
- the weight,
- Voltage,
- Serial number and
- CE marking.

NOTICE

The operating company must make sure that the rating plate is replaced if it becomes damaged or goes missing.

2.5 Operator control and display elements

The rail head grinding machine GP 210 +S features a control unit on its handlebar.

The following sections describe the individual controls and indicators on this unit.

2.5.1 LED display

The control unit has a backlit LED display that provides an overview of the grinding machine's status (please refer to Figure 2-3 on page 10).

When the electronics are on, the LED display will be turned on automatically as well. When the motor is turned off, the LED display will be turned off automatically.

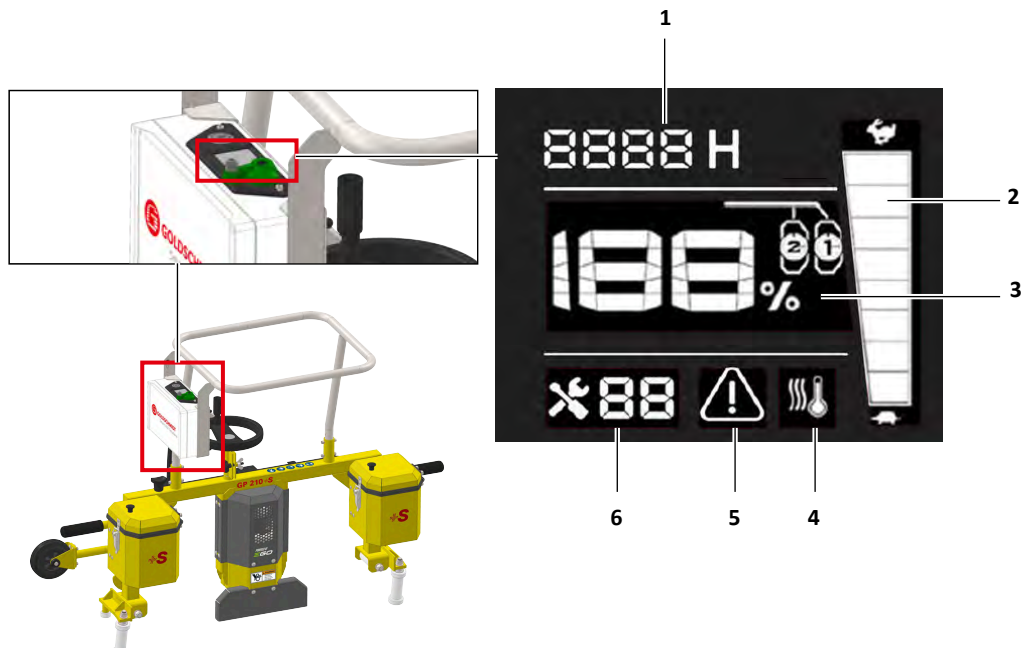

Fig. 2-3 LED display

1 Total run hours	3 Charge status indicator	5 Blockage indicator
2 Speed display	4 Overheating indicator	6 Fault indication

2.5.2 Key switch

The Key switch is found on the left side of the control unit (Figure 2-4 on page 10) and is used to turn on the electronics and the motor.

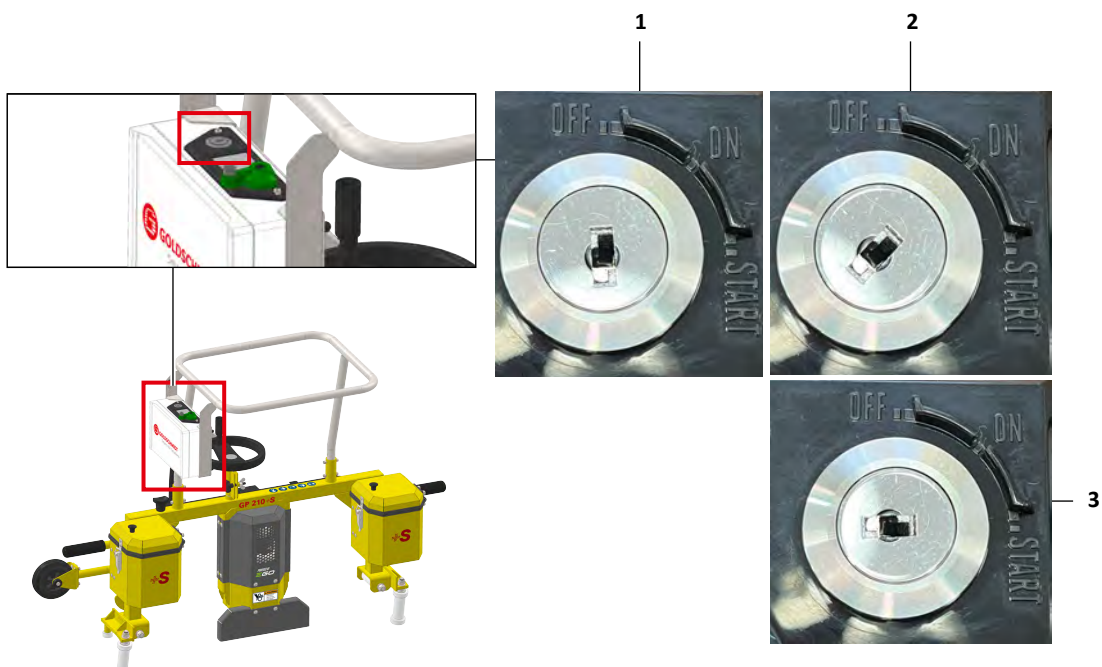

Fig. 2-4 Key switch

The Key switch has the following positions available:

Position	Description
1 "OFF" position	Turning the Key switch to the "OFF" position, will turn off the motor and the LED display.
2 "ON" position	Turning the Key switch to the "ON" position will turn on the electronics and the LED display.
3 "START" position	Turning the Key switch to the "START" position will turn on the motor and start the grinding operation.

2.5.3 Control lever

The Control lever is found on the right side of the control unit (Figure 2-5 on page 11). With the Control lever, the speed of the grinding wheel can be controlled manually across an infinitely variable range from min. 3000 rpm to max. 3400 rpm.

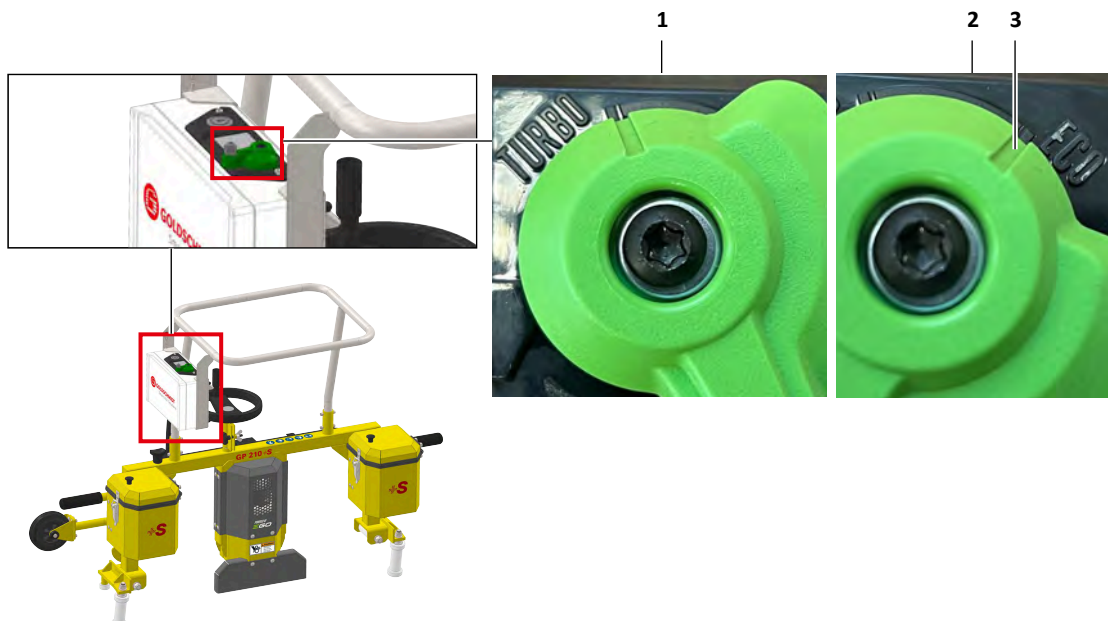



Fig. 2-5 Control lever

The Control lever can be moved to the following positions and in between:

Position	Description
1 "TURBO" position 	Moving the Control lever in the "TURBO" position will set the highest possible speed (3400 rpm) for the grinding process.
2 "ECO" position 	Moving the Control lever in the "ECO" position will set the lowest possible speed for the grinding process (3000 rpm).
3 Position indicator	Using the position indicator on the Control lever, the desired speed can be set.

The speed setting of the grinding wheel is also displayed as a scale graphic on the LED display:

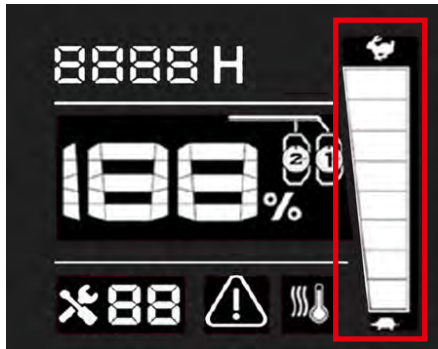

Fig. 2-6 LED display – speed

2.6 Colors and safety labels

2.6.1 Coloring

Table 2-2 on page 12 lists the colors for the various battery-powered rail head grinding machine GP 210 +S components:

Tab. 2-2 Coloring GP 210 +S

Color name / RAL code	Components
Jet black (RAL 9005)	Handles, star knob screw, handwheel
Traffic gray (RAL 7043)	guard, Motor covers
Gray aluminum (RAL 9007)	Handlebar
Golden yellow (RAL 1004)	Frame, battery compartment

2.6.2 Safety labels

NOTICE

If safety labels are damaged or go missing at any point in the machine's service life, the operating company must ensure that they are replaced properly. Make sure to check that the safety labels are in place and in good condition on a regular basis.

The mandatory action and warning labels shown in Figure 2-7 on page 13 can be found on the frame of the battery-powered rail head grinding machine GP 210 +S.



Fig. 2-7 Safety label (frame

- | | |
|--|---|
| 1 Mandatory action: wear protective clothing | 4 Mandatory action: wear safety footwear |
| 2 Mandatory action: wear work gloves | 5 Mandatory action: wear eye and hearing protection |
| 3 Mandatory action: wear a mask | |

On the drive unit of the battery-powered rail head grinding machine GP 210 +S, the mandatory action and warning labels are shown in Figure 2-8 on page 14 .

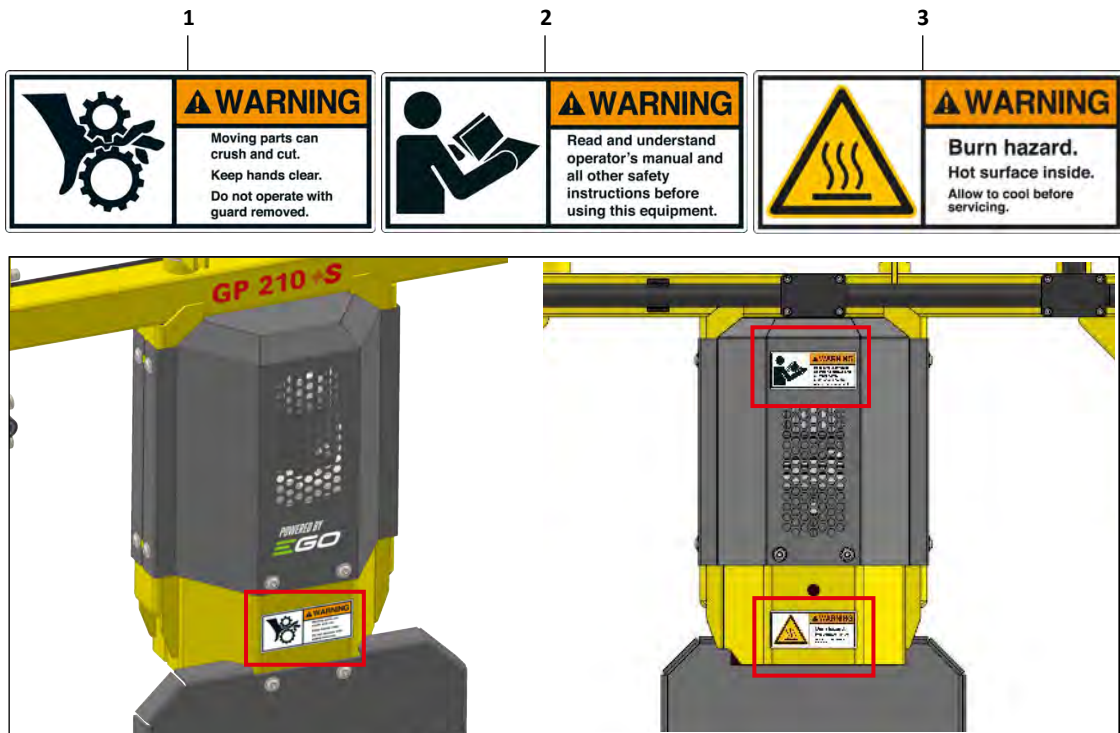

Fig. 2-8 Safety label (drive unit)

- | | |
|---|-------------------------------|
| <p>1 Warning: crush and cut hazard posed by moving parts</p> <p>2 Warning: read, understand, and observe the operation manual</p> | <p>3 Warning: burn hazard</p> |
|---|-------------------------------|

2.7 Safety systems

The following guards and safety devices are installed on the machine in order to prevent personal injury and environmental and property damage (please refer to Figure 2-9 on page 15).

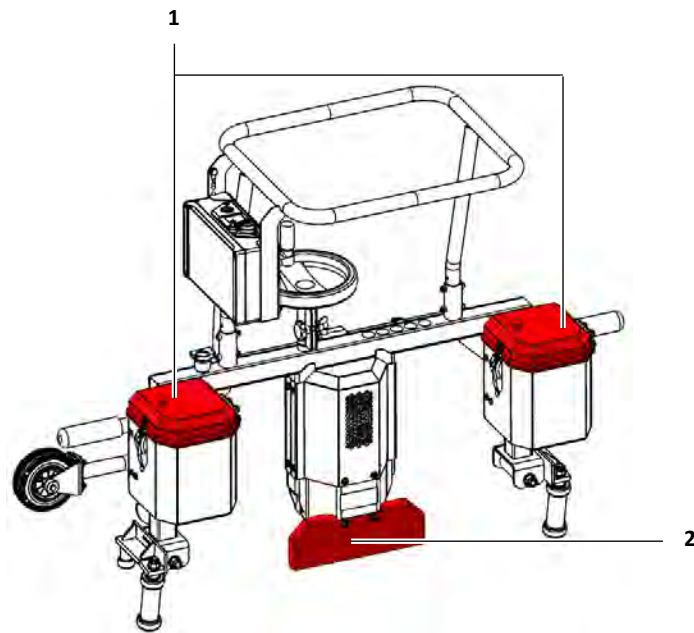

Fig. 2-9 Safety systems

Designation	Description
1 battery compartment cover (with toggle latch)	The battery compartment cover (with toggle latch) protects the EGO Power+ 56V-ARC-Lithium™ batteries from sparks, moisture, etc. The battery compartment cover (with toggle latch) must always be closed and latched in place during grinding.
2 guard	The guard protects the operator from flying sparks, dust and grinding particles.

2.8 Fire extinguisher

An operational CO₂ fire extinguisher must always be accessible in the immediate vicinity of the work area.

NOTICE

This fire extinguisher is not included and accordingly is the responsibility of the operating company.

2.9 What to do in case of emergency

If an emergency occurs, turn off the machine immediately and leave the danger zone as quickly as possible.

In the event of personal injury, provide first aid immediately.

In case of fire, take the required firefighting steps immediately.

2.10 Accessory devices

NOTICE Annex D - Accessories on Page V lists additional accessories.





2.10.1 Rechargeable battery

NOTICE To operate at full power, the machine needs two rechargeable EGO Power+ 56V-ARC-Lithium™ batteries. If only 1 rechargeable battery is in use, the device only operates at 60% power.





NOTICE Observe the battery and charger operation manuals provided by EGO when using and charging the batteries!

The batteries are EGO Power+ 56V-ARC-Lithium™ rechargeable batteries (12 Ah). Each battery features a charge status indicator. The various battery modes are described in Table 2-3 on page 16 below:

Tab. 2-3 Battery LED indicator modes

Modes		Description
Five LEDs light up green (continuous light)		80% ≤ charge level ≤ 100%
Four LEDs light up green (continuous light)		60% ≤ charge level < 80%
Three LEDs light up green (continuous light)		40% ≤ charge level < 60%
Two LEDs light up green (continuous light)		20% ≤ charge level < 40%
One LED lights up green (continuous light)		10% ≤ charge level < 20%

Tab. 2-3 Battery LED indicator modes <continuation>

Modes		Description
One LED flashes red		Charge level < 10%
Five LEDs flash red		Low voltage The battery is almost empty and needs to be charged.
Five LEDs light up red (continuous light)		The battery has overheated and needs to cool down.
No light on any of the LEDs		The rechargeable battery is switched off.

The control unit's LED display will show the batteries' charge status and the number of batteries that are inserted (please refer to Chapter Fig. 2-10 "LED display – battery charge status" on page 17).

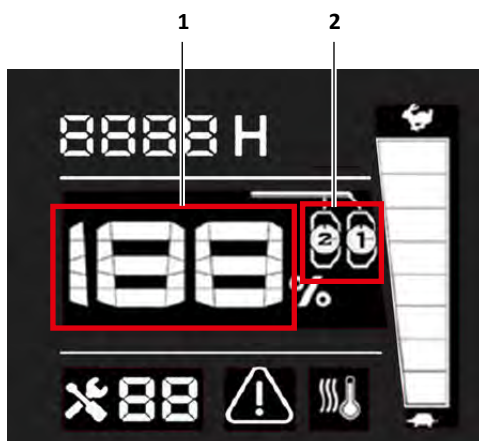

Fig. 2-10 LED display – battery charge status

Designation	Description
1 Charge status indicator	The Charge status indicator will show the current charge level of the battery or batteries as a percentage.
2 Battery quantity indicator	The battery quantity indicator will show the number of inserted batteries and the position.

2.10.2 Charger

NOTICE

Observe the battery and charger operation manuals provided by EGO when using and charging the batteries!

To charge the batteries correctly, make sure to use a "700 W RAPID+ Charger CH7000E" charger.

3 COMMISSIONING

Summary

Instructions that explain how to prepare the GP 210 +S for operation.

NOTICE

If you detect any issues, report them to your supervisor immediately. Do not put the machine back into operation until after these issues have been fixed and you receive approval for operating it again.

The following must be carried out before putting the machine into operation:

1. Check all included contents to make sure they are complete.
If any contents are missing, please contact the customer service team (please refer to Chapter 10 "Customer Service" on page 59).
2. Visually inspect the battery-operated rail head grinding machine GP 210 +S and the batteries for damage (cracks, broken parts, deformation, etc.).
Damaged components and machine parts will need to be replaced. Please contact the customer service team (please refer to Chapter 10 "Customer Service" on page 59).
3. Make sure that the batteries have been inserted correctly (please refer to Chapter 4.1 "Inserting the batteries" on page 22).
4. Check the batteries' charge status (please refer to Table 2-3 in Chapter 2.10.1 "Rechargeable battery" on page 16).
5. Make sure that the battery compartment cover (with toggle latch) is securely latched.
6. Check the rail head grinding machine for excess soiling.
Remove any excess soiling (please refer to Chapter 7.4 "Cleaning the GP 210 +S" on page 41).
7. Check that the guard is in place.



RISK OF INJURY.

There is a risk of injury posed by parts/particles flying around during grinding.

- **The rail head grinding machine must always be operated with a guard.**
- **Make sure that the guard is installed properly.**
- **Wear the specified personal safety equipment.**
- **Individuals not working with or on the machine must stay outside of the danger zone.**
- **Check every new grinding wheel for external damage and make sure to check its expiration date as well.**

8. Check the guard's condition.

Replace the guard if it is damaged and/or deformed (please refer to Chapter 7.7 "Changing the grinding wheel" on page 48).

9. Check all screw connections to make sure they are secure.

Retighten the screw connections if necessary (please refer to Chapter 7.8 "Checking the screw connections to make sure they are secure" on page 52).

10. Check that the grinding wheel has been installed correctly.

The grinding wheel must be installed without clearance. Correct the seating if necessary (please refer to Chapter 7.7 "Changing the grinding wheel" on page 48).

3.1 Functional test



RISK OF INJURY.

There is a risk of serious injury if the operator touches the rotating grinding wheel or reaches between the rotating grinding wheel and the guard.

- Keep your hands and legs away from the rotating grinding wheel.
- Never operate the rail head grinding machine without a guard.
- Remove all batteries before replacing the grinding wheel or carrying out any maintenance work.
- Individuals not working with or on the rail head grinding machine must stay outside the danger zone.
- Always wear the required personal protection equipment!

Follow the steps below in order to carry out the functional test properly.

1. Go through all the preparation steps (please refer to Chapter 3 "Commissioning" on page 19).
2. Hold the rail head grinding machine firmly by the handlebar.
3. Insert the key into the key switch on the left side of the control unit.
4. Turn the key 45° clockwise to the "ON" position to turn on the electronics.
The LED display will be turned on automatically.



5. Turn the key another 45° clockwise to the "START" position to turn on the motor.
The grinding wheel starts to rotate.

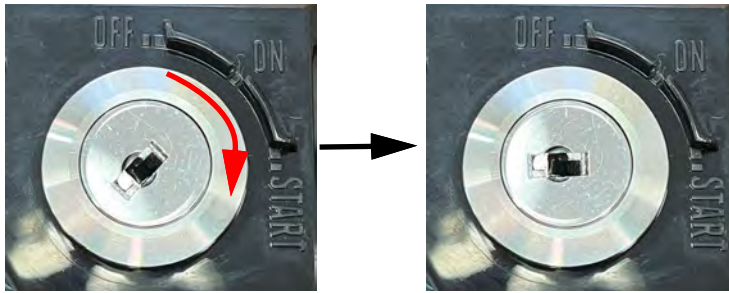

6. Move the control lever to the "TURBO" position to set the machine to its highest speed.

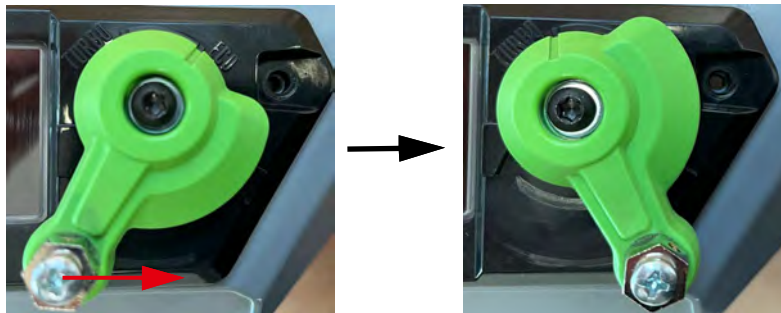

7. Let the grinding wheel rotate at full speed for a full minute. Check that the grinding wheel is running smoothly and does not wobble or produce abnormal vibrations.

The functional test is considered to be passed if the grinding wheel runs smoothly, does not wobble, and does not produce any abnormal vibrations.

NOTICE

If there are any issues, stop the functional test and start troubleshooting (please refer to Chapter 6 "Fault, Cause and Elimination" on page 32).

You can resume operation after fixing the detected issues.

8. Turn the key counterclockwise to the "OFF" position to turn off the electronics and the motor.

The LED display will be turned off automatically.

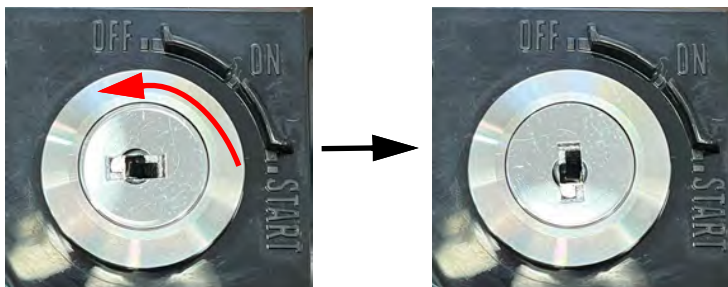

4 OPERATION

Summary

Instructions used to explain the GP 210 +S's main functions.



CAUTION

HEARING LOSS.

Noise levels during grinding may result in permanent hearing loss. Make sure to always wear hearing protection. Individuals who are not working with or on the grinding machine must stay at a minimum distance of 1.5 m / 59 inches. Agree on clear and effective hand signals for communication.

NOTICE

If you detect any issues, report them to your supervisor immediately. Do not put the machine back into operation until after these issues have been fixed and you receive approval for operating it again.

NOTICE

Wear personal protection equipment.

NOTICE

Do not place the rail head grinding machine in water or hose it down.

4.1 Inserting the batteries



WARNING

RISK OF INJURY.

There is a risk of injury due to fire and/or explosion. Damaged batteries and incorrectly handled batteries may behave in an unforeseeable manner, which can result in a fire or explosion and the associated risk of injury.

- Do not, under any circumstance, use any damaged or modified batteries!
- Properly dispose of all damaged batteries!
- Do not expose the batteries to fire or extreme temperatures!
- Follow all charging instructions and make sure to never charge the batteries outside of the temperature range specified in the manual provided by EGO (please refer to the EGO operation manual, Chapter 1.4 "Further applicable documents" on page 4).

NOTICE

Do not, under any circumstance, use damaged batteries.

NOTICE

To operate at full power, the machine needs two rechargeable EGO Power+ 56V-ARC-Lithium™ batteries. If only 1 rechargeable battery is in use, the device only operates at 60% power.

NOTICE

Observe the battery and charger operation manuals provided by EGO when using and charging the batteries!

NOTICE

Make sure to only use EGO Power+ 56V-ARC-Lithium™ batteries (two units) or other batteries approved by the manufacturer.

Follow the steps below to insert the batteries correctly:

1. Open the toggle latch and then open the battery compartment cover (with toggle latch).

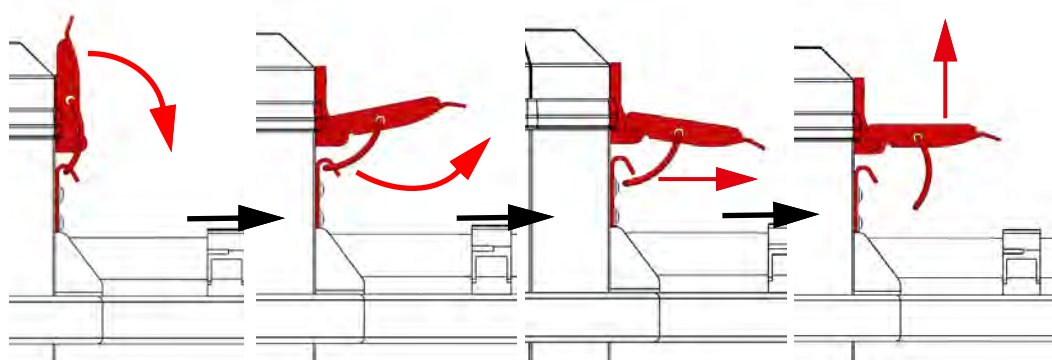

2. Align the rechargeable battery ribs with the connector guide slots in the battery holder and slide the battery all the way into the battery holder.

When the battery has been inserted properly all the way, you will hear it click into place. Repeat for the second battery.

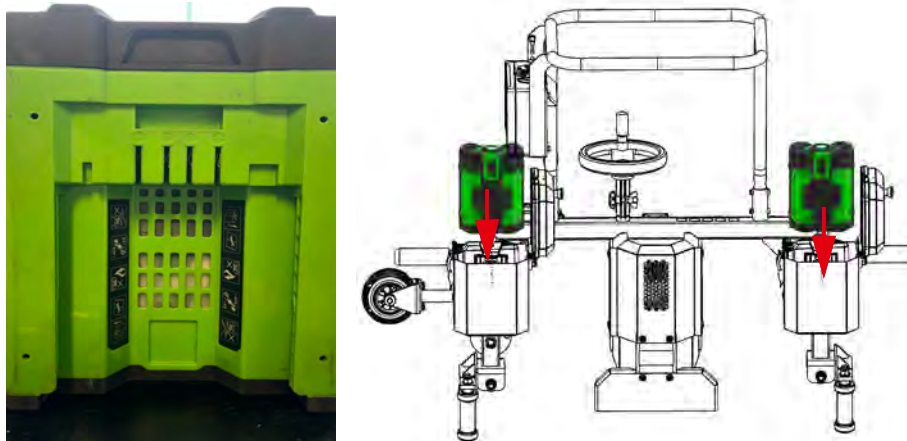

3. Close the battery compartment cover (with toggle latch) and then close the toggle latch.

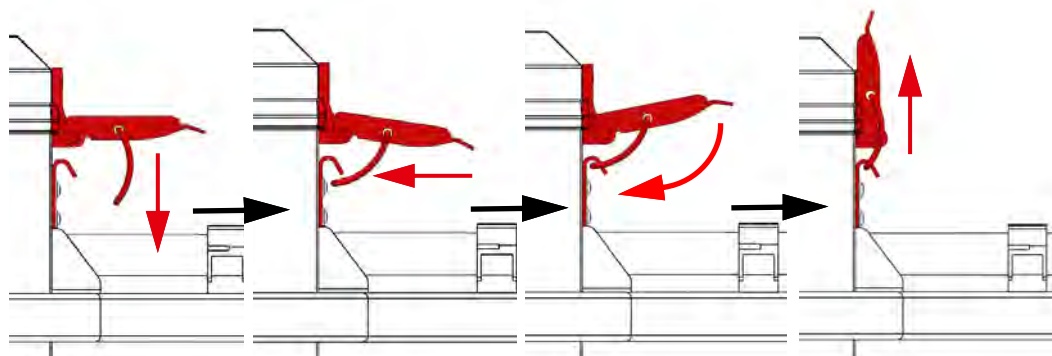

4.2 Grinding



HOT SURFACES.

Hot surfaces pose a burn hazard.

The surfaces of the grinding wheel, the guard, and/or the rail may be hot after grinding and result in burns or other irreversible injuries if touched.

- Make sure to always wear all necessary personal protection equipment (especially work gloves).
- Let the components cool down first before changing the grinding wheel or carrying out maintenance work.
- Let the rail cool down after welding (below 40 °C / 104 °F).



RISK OF INJURY.

There is a risk of serious injury if the operator touches the rotating grinding wheel or reaches between the rotating grinding wheel and the guard.

- Keep your hands and legs away from the rotating grinding wheel.
- Never operate the rail head grinding machine without a guard and a
- Always wear the required personal protection equipment!



CRUSH HAZARD.

There is a risk of injury due to crushing if the operator reaches between the Guide roller, the guide roller, and the rail.

- Do not, under any circumstance, reach between the Guide roller and the rail!
- Always wear the required personal protection equipment!

Follow the steps below in order to do grinding work correctly:

1. Go through all the preparation steps (please refer to Chapter 3 "Commissioning" on page 19).
2. Pull out the locking bolt and fold the transport roller upwards through 90°.
The locking bolt engages in the nearest position automatically.

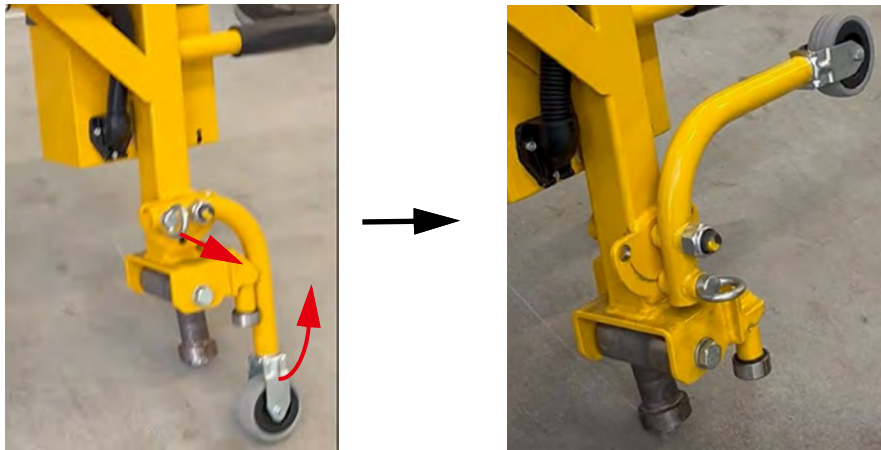

3. Place the rail head grinding machine on the rail so that the rail is located between the Guide rollers and the rail rollers are in contact with the rail.



CAUTION

CRUSH HAZARD.

There is a crush hazard when setting the machine on a rail. Do not, under any circumstance, reach between the rail and the GP 210 +S battery-powered profile grinder. To set down the machine, use the handles intended for that purpose.

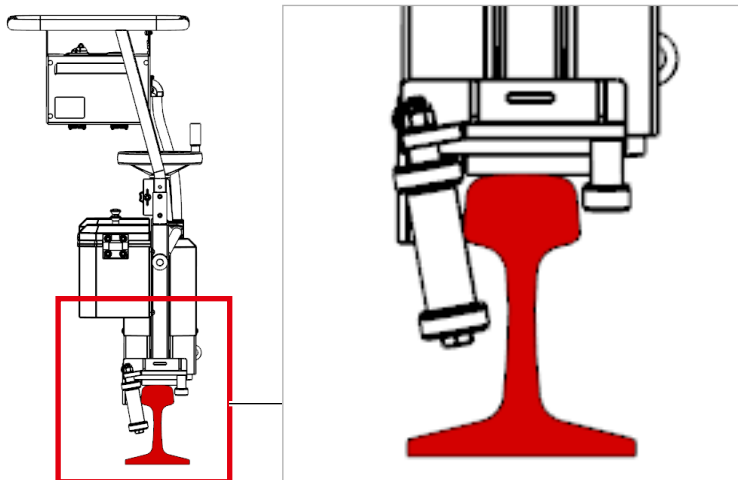

To set down the machine on the rail, use the handles or handlebar provided.

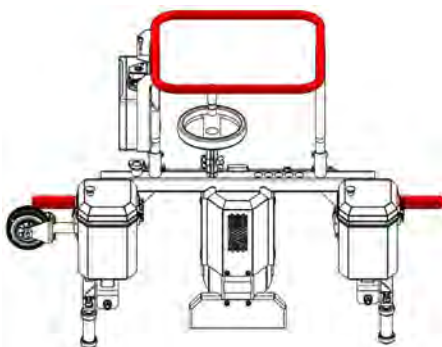

4. Hold the rail head grinding machine firmly by the handlebar.

5. Insert the key into the key switch on the left side of the control unit.
6. Turn the key 45° clockwise to the "ON" position to turn on the electronics.
The LED display will be turned on automatically.



7. Turn the key another 45° clockwise to the "START" position to turn on the motor.
The grinding wheel starts to rotate.

**CAUTION****RISK OF INJURY.**

There is a risk of injury due to abnormal vibrations.
If you notice any abnormal vibrations while working with the rail head grinding machine, stop operating the machine immediately.

- Start troubleshooting (please refer to Chapter 6 "Fault, Cause and Elimination" on page 32).
- Turn the rail head grinding machine off until the cause of the vibrations has been found and fixed.
- Check to make sure that the grinding wheel is properly mounted and adjust it if necessary (please refer to Chapter 7 "Maintenance and Care" on page 37).



8. Using both hands, hold the rail head grinding machine firmly by the handlebar.
9. Move the battery-operated rail head grinding machine GP 210 +S as necessary to grind the rail head.
10. Adjust the speed if necessary during grinding (please refer to Chapter 4.3 "Adjusting the speed" on page 27).
11. Turn the key counterclockwise to the "OFF" position to turn off the electronics and the motor.
The LED display will be turned off automatically.
The grinding wheel is stationary

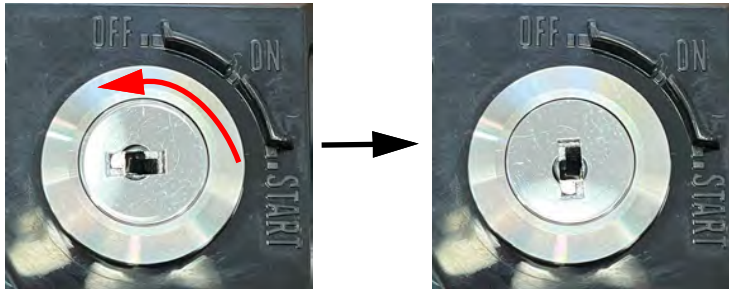

12. Remove the key from the key switch on the left side of the control unit.
13. Remove the battery-operated rail head grinding machine GP 210 +S from the rail.

**CRUSH HAZARD.**

There is a crush hazard when removing the machine from the rail.

Do not, under any circumstance, reach between the rail and the GP 210 +S battery-powered profile grinder.

To remove the machine from the rail, use the handles intended for that purpose.

**RISK OF INJURY.**

There is a risk of injury posed by the machine's weight.

The rail head grinding machine weighs 40 kg / 88.18 lbs without grinding wheel and batteries. There is a risk of injury when the machine is being transported.

- Carrying the rail head grinding machine is mandated as a two-person job.
- Use the handles to carry the rail head grinding machine.
- Always wear safety footwear.

NOTICE

Make absolutely sure that the grinding wheel has stopped before removing the grinding machine from the rail.

4.3 Adjusting the speed

Follow the steps below to adjust the machine's speed correctly:

1. Move the Control lever on the control unit to the position you want in order to adjust the speed.

The position indicator shows the speed you have set.

Move the Control lever on the control unit to the right to increase the speed. The "TURBO" position marks the fastest possible speed.

Move the Control lever on the control unit to the left to decrease the speed. The "ECO" position marks the slowest possible speed.



The control unit's LED display will show the set speed.

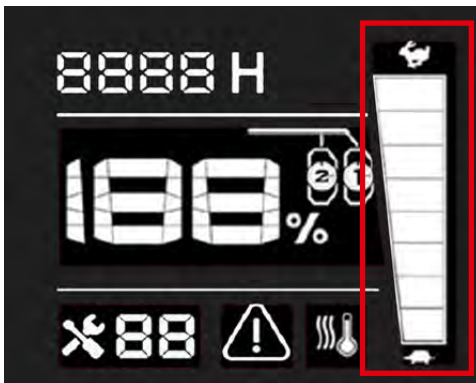

4.4 Removing the batteries



WARNING

RISK OF INJURY.

There is a risk of injury due to fire and/or explosion. Damaged batteries and incorrectly handled batteries may behave in an unforeseeable manner, which can result in a fire or explosion and the associated risk of injury.

- Do not, under any circumstance, use any damaged or modified batteries!
- Properly dispose of all damaged batteries!
- Do not expose the batteries to fire or extreme temperatures!
- Follow all charging instructions and make sure to never charge the batteries outside of the temperature range specified in the manual provided by EGO (please refer to the EGO operation manual, Chapter 1.4 "Further applicable documents" on page 4).

NOTICE

Do not, under any circumstance, use damaged batteries.

NOTICE

To operate at full power, the machine needs two rechargeable EGO Power+ 56V-ARC-Lithium™ batteries. If only 1 rechargeable battery is in use, the device only operates at 60% power.

NOTICE

Observe the battery and charger operation manuals provided by EGO when using and charging the batteries!

NOTICE

Make sure to only use EGO Power+ 56V-ARC-Lithium™ batteries (two units) or other batteries approved by the manufacturer.

Follow the steps below to remove the batteries correctly:

1. Turn the key counterclockwise to the "OFF" position to turn off the electronics and the motor.

The grinding wheel is stationary

The LED display will be turned off automatically.

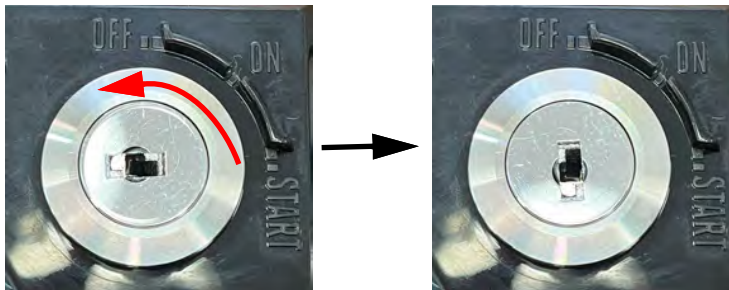

2. Open the toggle latch and then open the battery compartment cover (with toggle latch).

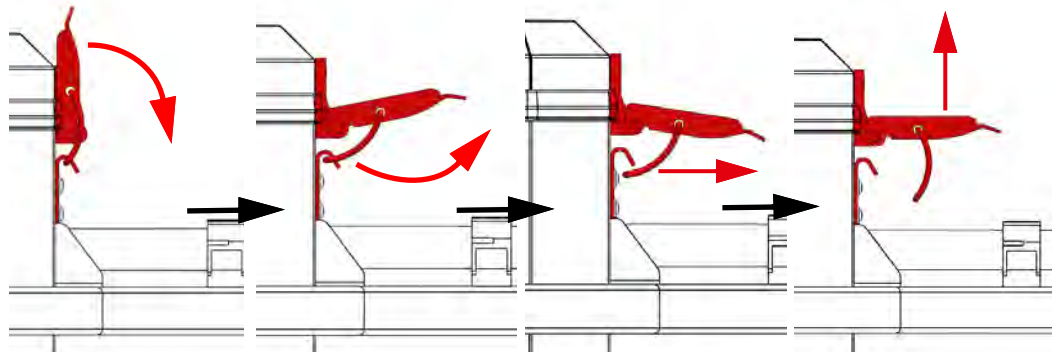

3. Press the actuator down on the battery holder and pull the rechargeable battery upwards and out of its holder.

Repeat for the second battery.

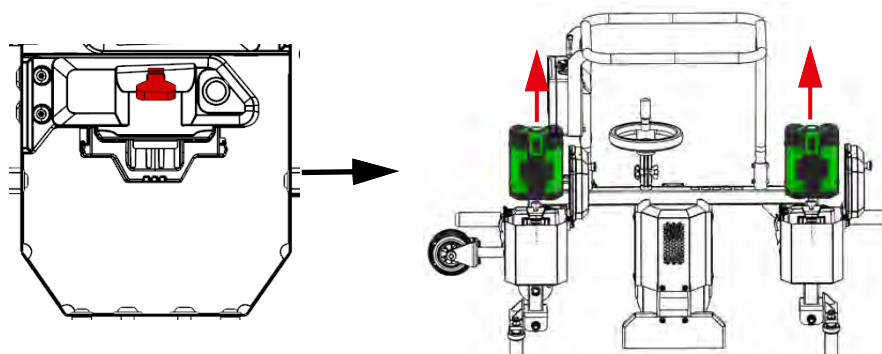

4. Close the battery compartment cover (with toggle latch) and then close the toggle latch.

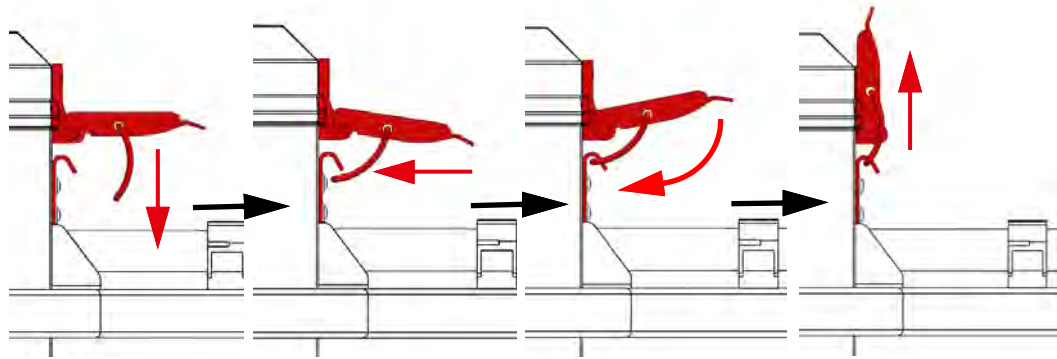

5 DECOMMISSIONING (SHUTDOWN)

Summary

Instructions used to explain how to shut down the GP 210 +S as preparation for maintenance, transportation, or storage.

Follow the steps below in order to shut down the machine properly.

1. Hold the rail head grinding machine firmly by the handlebar.
2. Turn the key counterclockwise to the "OFF" position to turn off the electronics and the motor.

The grinding wheel is stationary

The LED display will be turned off automatically.



3. Remove the key from the key switch on the left side of the control unit.
4. Remove the batteries (please refer to Chapter 4.4 "Removing the batteries" on page 28).
5. Remove the battery-operated rail head grinding machine GP 210 +S from the rail.

CAUTION

CRUSH HAZARD.

There is a crush hazard when removing the machine from the rail.

Do not, under any circumstance, reach between the rail and the battery-operated rail head grinding machine GP 210 +S.

To remove the machine from the rail, use the handles intended for that purpose.

CAUTION

RISK OF INJURY.

There is a risk of injury posed by the machine's weight.

The rail head grinding machine weighs 40 kg / 88.18 lbs without grinding wheel and batteries. There is a risk of injury when the machine is being transported.

- Carrying the rail head grinding machine is mandated as a two-person job.
- Use the handles to carry the rail head grinding machine.
- Always wear safety footwear.

NOTICE

Make absolutely sure that the grinding wheel has stopped before removing the grinding machine from the rail.

6 FAULT, CAUSE AND ELIMINATION

Summary

Identifying problems and fixing them.



RISK OF INJURY.

There is a risk of injury posed by repairs that are not carried out correctly.

Repairs to the rail head grinding machine must be carried out exclusively by Elektro-Thermit GmbH & Co. KG or specially trained personnel.

- Work on electrical system components must be carried out exclusively by qualified electricians.
- Parts and components must be replaced exclusively with identical spare parts. When replacing a component, make absolutely sure to observe all the component manufacturer's instructions and specifications.

NOTICE

All maintenance, servicing, and inspection work must be carried out exclusively by trained specialized personnel.

NOTICE



Wear the required personal protection equipment.

NOTICE

If necessary, contact the customer service team (please refer to Chapter 10 "Customer Service" on page 59) in order to get information for maintenance steps or repairs.

The following Table 6-1 on page 32 lists potential problems, their cause, and how to fix them.

FCE 6-1 Fault, cause and elimination

Fault/Defect	Cause	Elimination
1 battery LED flashes red 	Battery charge level < 10%	1. Charge the battery with a compatible charger.
Five battery LEDs flash red 	The battery is almost empty and needs to be charged immediately.	

FCE 6-1 Fault, cause and elimination <continuation>

Fault/Defect	Cause	Elimination
<p>Five battery LEDs light up red (continuous light)</p> 	<p>Battery overheating</p>	<p>1. Let the battery cool down.</p>
<p>Wobbling, abnormal vibrations, and/or noise</p>	<p>Problems with the grinding drive's concentricity</p>	<p>1. Shut down the machine (please refer to Chapter 5 "Decommissioning (Shut-down)" on page 31).</p> <p>2. Check the grinding wheel for damage. Damaged grinding wheels must be replaced.</p> <p>3. Replace the grinding wheel if damaged (please refer to Chapter 7.7 "Changing the grinding wheel" on page 48).</p>





FCE 6-1 **Fault, cause and elimination** <continuation>

Fault/Defect	Cause	Elimination
It is not possible to switch on the rail head grinding machine.	No batteries have been inserted	<ol style="list-style-type: none"> 1. Check to make sure that you have inserted the batteries. 2. Insert the batteries (please refer to Chapter 4.1 "Inserting the batteries" on page 22). 3. Go through all the preparation steps (please refer to Chapter 3 "Commissioning" on page 19).
	Batteries not inserted correctly	<ol style="list-style-type: none"> 1. Check to make sure that the battery or batteries have been inserted all the way. 2. Insert the battery or batteries properly. Align the battery ribs with the connector guide slots and slide the battery all the way into the battery holder. When the battery has been inserted properly all the way, you will hear it click into place. Repeat for the second battery. 3. Go through all the preparation steps (please refer to Chapter 3 "Commissioning" on page 19).
	The battery is flat	<ol style="list-style-type: none"> 1. Charge the battery with a compatible charger (please refer to the operation manual provided by EGO).



6.1 **Error codes on the LED display**

Table 6-2 on page 35 below lists various error codes that the LED display can show, as well as their cause and how to fix them.

FCE 6-2 Error codes

Error code	Cause	Elimination
	Blocked rotor protection	<ol style="list-style-type: none"> 1. Shut down the machine (please refer to Chapter 5 "Decommissioning (Shutdown)" on page 31). 2. Check for blockages close to the area where you are working. Remove any blockages. 3. Go through all the preparation steps (please refer to Chapter 3 "Commissioning" on page 19). If the error code is shown again, please contact the customer service team (please refer to Chapter 10 "Customer Service" on page 59).
	Low voltage	<ol style="list-style-type: none"> 1. Shut down the machine (please refer to Chapter 5 "Decommissioning (Shutdown)" on page 31). 2. Charge the battery/batteries with a compatible charger (please refer to the operation manual provided by EGO). 3. Once the battery is fully charged, insert it once again (please refer to Chapter 4.1 "Inserting the batteries" on page 22).
	Overheated battery	<ol style="list-style-type: none"> 1. Shut down the machine (please refer to Chapter 5 "Decommissioning (Shutdown)" on page 31). 2. Let the battery cool down.
	Overheated drive unit	<ol style="list-style-type: none"> 1. Shut down the machine (please refer to Chapter 5 "Decommissioning (Shutdown)" on page 31). 2. Check the air filter for impurities and clean them out if necessary (please refer to Chapter 7.5 "Cleaning the air filter" on page 42). 3. Let the drive unit cool down. 4. Reduce the work load.

FCE 6-2 Error codes <continuation>

Error code	Cause	Elimination
	Main board overcurrent protection	1. Reduce the work load.
	Communication error	1. Please contact the customer service team (please refer to Chapter 10 "Customer Service" on page 59).

7 MAINTENANCE AND CARE

Summary

Overview of maintenance and repair tasks and the materials required for them, as well as instructions on how to carry them out.



WARNING

RISK OF INJURY.

There is a risk of injury.

Operating and maintenance personnel must have the required qualifications and be able to carry out the respective tasks reliably.

- The manager in question must define the corresponding personnel's responsibilities and supervision in detail.
- Everyone carrying out work on the machine must have received detailed briefing before that. This briefing must be documented in writing.
- The operations manager in question must make sure that all personnel has fully understood the contents of the operation and maintenance manuals.



WARNING

RISK OF INJURY.

Incorrect, untimely, or poorly considered maintenance work may result in personal injury or to damage to the machine.

- Remove all batteries before carrying out any maintenance work.
- Observe the manufacturer's maintenance intervals and instructions, as well as all applicable guidelines.
- Parts and components must be replaced exclusively with identical spare parts. When replacing a component, make absolutely sure to observe all the component manufacturer's instructions and specifications.



WARNING

RISK OF INJURY.

There is a risk of injury posed by repairs that are not carried out correctly.

Repairs to the rail head grinding machine must be carried out exclusively by Elektro-Thermit GmbH & Co. KG or specially trained personnel.

- Work on electrical system components must be carried out exclusively by qualified electricians.
- Parts and components must be replaced exclusively with identical spare parts. When replacing a component, make absolutely sure to observe all the component manufacturer's instructions and specifications.

**RISK OF INJURY.**

There is a risk of serious injury if the operator touches the rotating grinding wheel or reaches between the rotating grinding wheel and the guard.

- Keep your hands and legs away from the rotating grinding wheel.
- Never operate the rail head grinding machine without a guard.
- Remove all batteries before replacing the grinding wheel or carrying out any maintenance work.
- Individuals not working with or on the rail head grinding machine must stay outside the danger zone.
- Always wear the required personal protection equipment!

**RISK OF INJURY.**

Putting the machine back into operation accidentally may result in injury.

Make sure that the rail head grinding machine GP 210 +S cannot be put back into operation accidentally during maintenance and repair work by removing the batteries.



Environmentally hazardous substances must be properly disposed of in compliance with all applicable requirements and regulations.

Make sure to observe the manufacturer's data sheets and safety data sheets.

Comply with the disposal regulations that apply in the relevant U.S. state!

For more detailed information, please refer to Chapter 9 "Disposal" on page 58.

NOTICE

All maintenance, servicing, and inspection work must be carried out exclusively by trained specialized personnel (please refer to Chapter 1.3 "Requirements for operators" on page 1).

NOTICE

Wear the required personal protection equipment (please refer to Chapter 1.3.3 "Personal protection equipment" on page 3).

NOTICE

Damage, unusual noises, overheating, and/or vibrations are all things you should be on the lookout for.

NOTICE

Proper and timely maintenance will lengthen the machine's service life, ensure availability, and help prevent unwanted downtimes. The recommended maintenance intervals must be observed.

NOTICE

The components in the rail head grinding machine are subject to various maintenance intervals that depend on how the machine is used. These maintenance intervals must be determined by the company operating the machine as part of the corresponding hazard and risk assessments. Observe the requirements in all applicable guidelines.

NOTICE

The operating company must document all maintenance.

NOTICE

Use genuine spare parts and suitable tools exclusively.

7.1 Maintenance schedule

The maintenance schedule shows the interval at which maintenance tasks must be carried out while taking into account specific maintenance steps (please refer to Table 7-1 on page 39).

Tab. 7-1 Maintenance schedule

Maintenance task	interval					
	Every time before putting the machine into operation	Daily / after the end of each shift	Every 80 operating hours	Every 100 operating hours	Annually	As necessary
Visual inspection of the GP 210 +S	X	X				X
Visual inspection and condition check Safety labels and rating plate				X		X
Cleaning the GP 210 +S		X				X
Cleaning the air filter		X				X
Changing the air filter			X			X
Changing the grinding wheel						X
Checking the screw connections to make sure they are secure			X			X

7.2 Visual inspection of the GP 210 +S

Ambient conditions

No special ambient conditions need to be observed.

Personnel

Specialized personnel

Tools and materials

-

Maintenance 7-1 Visual inspection

Maintenance steps	Tools / materials
<p>1. Switch off the device</p> <p>1- 001 Shut down the machine (please refer to Chapter 5 "Decommissioning (Shutdown)" on page 31).</p>	
<p>2. Visual inspection of general condition</p> <p>2- 001 Carry out a visual inspection checking for damage, cracks, broken parts, and dents.</p> <p>Damaged components must not be put into operation and must be replaced.</p> <p>Please contact the customer service team (please refer to Chapter 10 "Customer Service" on page 59).</p> <p>2- 002 Carry out a visual inspection of the grinding wheel.</p> <p>Damaged and worn out grinding wheels must not be put into operation and must be replaced.</p> <p>Please refer to Chapter 7.7 "Changing the grinding wheel" on page 48).</p> <p>2- 003 Check the grinding wheel's expiration date.</p> <p>Expired grinding wheels must not be put into operation and must be replaced.</p> <p>Please refer to Chapter 7.7 "Changing the grinding wheel" on page 48).</p> <p>2- 004 Check the guard for damage and wear.</p> <p>A damaged or missing guard must not be put into operation and must be replaced.</p> <p>Please contact the customer service team (please refer to Chapter 10 "Customer Service" on page 59).</p>	
<p>3. Switch on the device</p> <p>3- 001 Go through all the preparation steps (please refer to Chapter 3 "Commissioning" on page 19).</p>	

7.3 Visual inspection and condition check Safety labels and rating plate

Ambient conditions
No special ambient conditions need to be observed.

Personnel

Specialized personnel

Tools and materials

Rating plate

Safety labels as needed

Maintenance 7-2 Visual inspection and condition check of safety labels and rating plate

Maintenance steps	Tools / materials
<p>1. Switch off the device</p> <p>1- 001 Shut down the machine (please refer to Chapter 5 "Decommissioning (Shutdown)" on page 31).</p>	
<p>2. Visual inspection and condition check</p> <p>2- 001 Check that all safety labels are present and legible. Missing and illegible safety labels must be replaced. For more detailed information, please refer to Chapter 2.6.2 "Safety labels" on page 12.</p> <p>2- 002 Check that the rating plate is present and legible. If the rating plate is missing or illegible, it must be replaced. For more detailed information, please refer to Chapter 2.4.1 "Rating plate" on page 8.</p>	<p>Safety labels</p> <p>Rating plate</p>
<p>3. Switch on the device</p> <p>3- 001 Go through all the preparation steps (please refer to Chapter 3 "Commissioning" on page 19).</p>	

7.4 Cleaning the GP 210 +S

**WARNING****RISK OF INJURY.**

There is a risk of metal swarf causing eye injuries when removing impurities with compressed air.

Make sure to wear safety eyewear and protective clothing during cleaning work.

NOTICE

The machine must be cleaned at the end of each shift every time it is used.

NOTICE

Do not place the rail head grinding machine in water or hose it down.

Ambient conditions

No special ambient conditions need to be observed.

Personnel

Specialized personnel

Tools and materials**Quantity**

Cleaning cloth (lint-free)

1

Blow gun

1

Maintenance 7-3 Cleaning

Maintenance steps	Tools / materials
1. Switch off the device 1- 001 Shut down the machine (please refer to Chapter 5 "Decommissioning (Shutdown)" on page 31).	-
2. Cleaning 2- 001 Remove grinding dust with a blow gun at a distance of 30 cm every time after you use the machine. 2- 002 Remove excess soiling with an appropriate cleaning cloth.	Blow gun Cleansing tissue
<div style="display: flex; align-items: center;">  <div> <p>Observe the following when cleaning the machine:</p> <ul style="list-style-type: none"> • Do not, under any circumstance, let water get on or in the motor. • Do not, under any circumstance, use combustible and/or highly flammable cleaning agents. • Make sure that there are no paper residues and/or cleaning cloths left on the motor. • Do not hold the compressed air gun in the ventilation slots from the outside to prevent impurities from entering the system. </div> </div>	
3. Switch on the device 3- 001 Go through all the preparation steps (please refer to Chapter 3 "Commissioning" on page 19).	

7.5 Cleaning the air filter**Ambient conditions**

No special ambient conditions need to be observed.

Personnel
Specialized personnel

Tools and materials	Quantity
4 mm Allen key	1
Blow gun	1

Maintenance 7-4 Cleaning the air filter

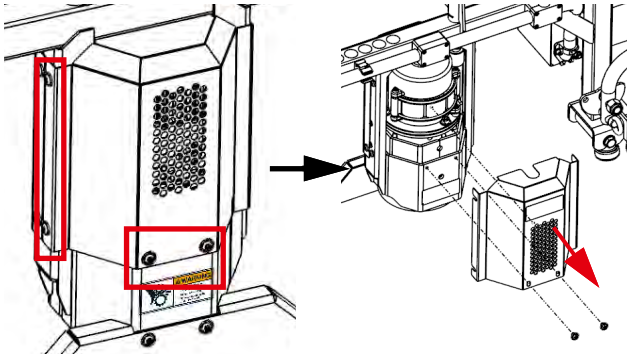
Maintenance steps	Tools / materials
<p>1. Switch off the device</p> <p>1- 001 Shut down the machine (please refer to Chapter 5 "Decommissioning (Shutdown)" on page 31).</p>	-
<p>2. Remove the cover</p> <p>2- 001 Loosen the M6 pan-head screw (M6 x 16) on the side by turning it anti-clockwise with a 4 mm Allen key.</p> <p>There are two M6 hex bolts on the left side and two on the right side.</p> <p>2- 002 Loosen the M6 pan-head screw (M6 x 8) by turning it counter-clockwise with a 4 mm Allen key.</p> <p>There are two M6 pan-head screws on the cover.</p> <p>2- 003 Remove the cover and set it aside.</p>	<p>4 mm Allen key</p> <p>4 mm Allen key</p>
	

Maintenance 7-4 Cleaning the air filter <continuation>

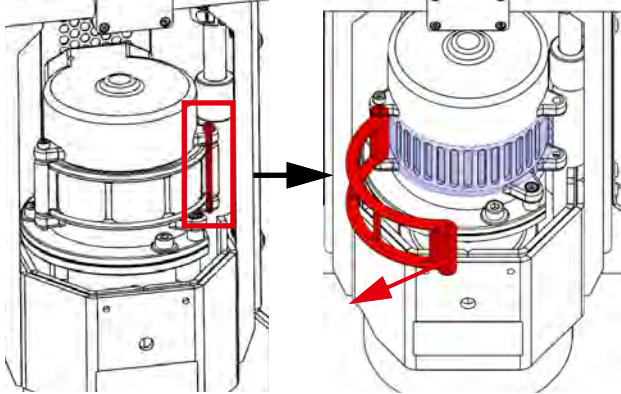
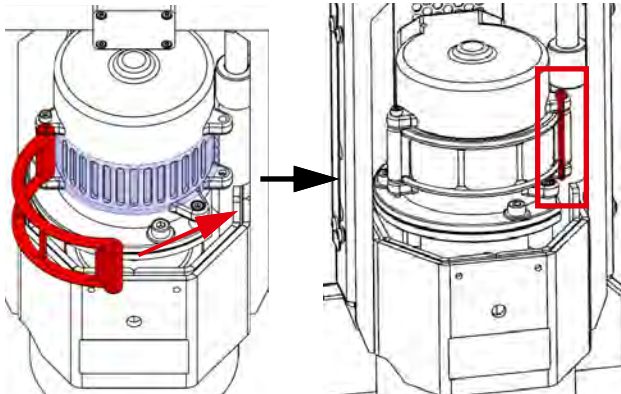
Maintenance steps	Tools / materials
<p>2- 004 Loosen the M5 pan-head screw (M5 x 70) by turning it counter-clockwise with a 4 mm Allen key.</p> <p>2- 005 Open the filter holder and remove the air filter.</p> 	4 mm Allen key
<p>3. Cleaning the air filter</p> <p>3- 001 Carefully clean the air filter with a blow gun. Hold the blow gun at a distance of 30 cm from the cover.</p>	Blow gun
<p>4. Install the cover</p> <p>4- 001 Install the air filter.</p> <p>4- 002 Close the filter holder.</p> <p>4- 003 Turn the M5 pan-head screw (M5 x 70) counter-clockwise firmly using a 4 mm Allen key.</p> 	4 mm Allen key

Maintenance 7-4 Cleaning the air filter <continuation>

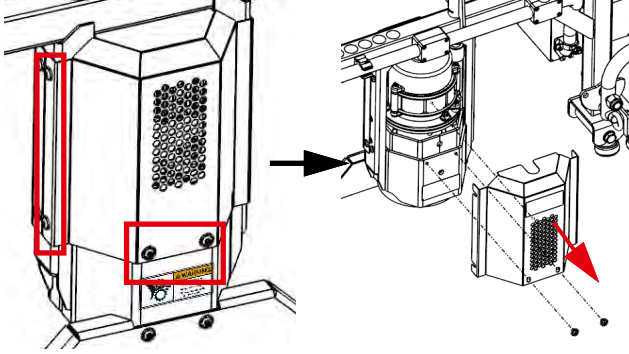
Maintenance steps	Tools / materials
<p>4- 004 Fit the cover.</p> <p>4- 005 Tighten the M6 pan-head screw (M6 x 16) on the side by turning it clockwise with a 4 mm Allen key. There are two M6 hex bolts on the left side and two on the right side.</p> <p>4- 006 Tighten the M6 pan-head screw (M6 x 8) by turning it clockwise with a 4 mm Allen key. There are two M6 pan-head screws on the cover.</p>	<p>Shroud</p> <p>4 mm Allen key</p> <p>4 mm Allen key</p>
	
<p>5. Switch on the device</p> <p>5- 001 Go through all the preparation steps (please refer to Chapter 3 "Commissioning" on page 19).</p>	-

7.6 Changing the air filter

Ambient conditions
No special ambient conditions need to be observed.

Personnel
Specialized personnel

Tools and materials	Quantity
4 mm Allen key	1
Air filter	1

Maintenance 7-5 Changing the air filter

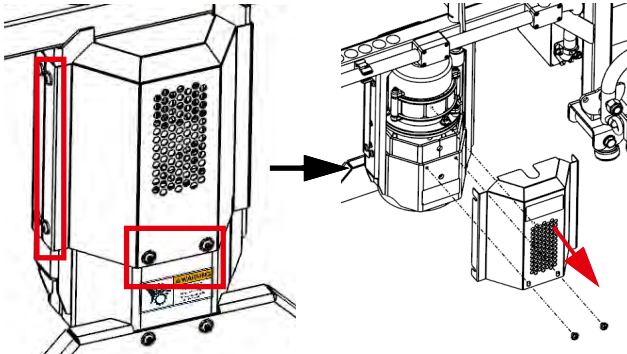
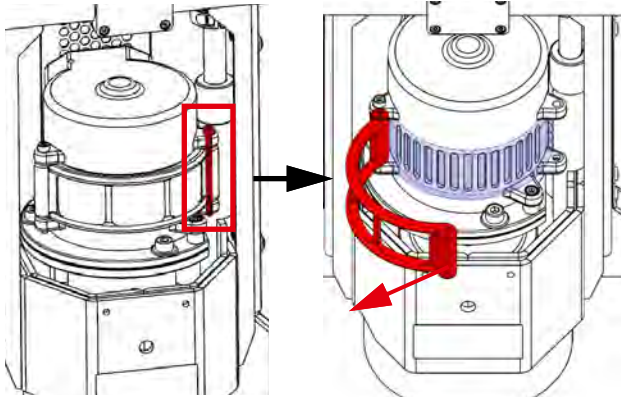
Maintenance steps	Tools / materials
<p>1. Switch off the device</p> <p>1- 001 Shut down the machine (please refer to Chapter 5 "Decommissioning (Shutdown)" on page 31).</p>	-
<p>2. Dismantle the cover and remove the air filter</p> <p>2- 001 Loosen the M6 pan-head screw (M6 x 16) on the side by turning it anti-clockwise with a 4 mm Allen key.</p> <p>There are two M6 hex bolts on the left side and two on the right side.</p> <p>2- 002 Loosen the M6 pan-head screw (M6 x 8) by turning it counter-clockwise with a 4 mm Allen key.</p> <p>There are two M6 pan-head screws on the cover.</p> <p>2- 003 Remove the cover and set it aside.</p>  <p>2- 004 Loosen the M5 pan-head screw (M5 x 70) by turning it counter-clockwise with a 4 mm Allen key.</p> <p>2- 005 Open the filter holder and remove the air filter.</p> 	<p>4 mm Allen key</p> <p>4 mm Allen key</p> <p>4 mm Allen key</p>
<p>NOTICE Comply with the disposal regulations that apply in the relevant U.S. state!</p>	
<p>3. Install the air filter and fit the cover</p>	

Maintenance 7-5 Changing the air filter <continuation>

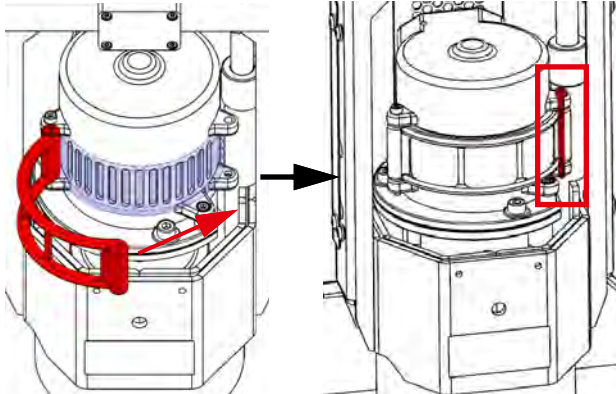
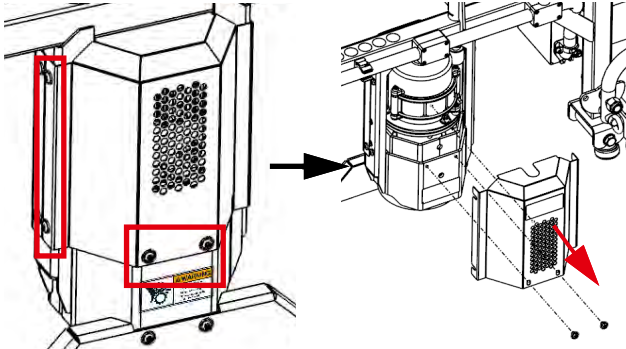
Maintenance steps	Tools / materials
<p>3- 001 Insert the new air filter.</p> <p>3- 002 Close the filter holder.</p> <p>3- 003 Tighten the M5 pan-head screw (M5 x 70) by turning it clockwise with a 4 mm Allen key.</p> 	<p>Air filter</p> <p>4 mm Allen key</p>
<p>3- 004 Fit the cover.</p> <p>3- 005 Tighten the M6 pan-head screw (M6 x 16) on the side by turning it clockwise with a 4 mm Allen key. There are two M6 hex bolts on the left side and two on the right side.</p> <p>3- 006 Tighten the M6 pan-head screw (M6 x 8) by turning it clockwise with a 4 mm Allen key. There are two M6 pan-head screws on the cover.</p> 	<p>Shroud</p> <p>4 mm Allen key</p> <p>4 mm Allen key</p>
<p>4. Switch on the device</p> <p>4- 001 Go through all the preparation steps (please refer to Chapter 3 "Commissioning" on page 19).</p>	<p>-</p>

7.7 Changing the grinding wheel



WARNING

HOT SURFACES.

Hot surfaces pose a burn hazard.

The surfaces of the grinding wheel, the guard, and/or the rail may be hot after grinding and this can cause burns or other irreversible injuries if touched.

- Make sure to always wear all necessary personal protection equipment (especially work gloves).
- Let the components cool down first before changing the grinding wheel or carrying out maintenance work.
- Let the rail cool down after welding (below 40 °C / 104 °F).

NOTICE

Before use, check the grinding wheel for damage and make sure that it has not expired yet.

Never, under any circumstance, use damaged or out-of-date grinding wheels.

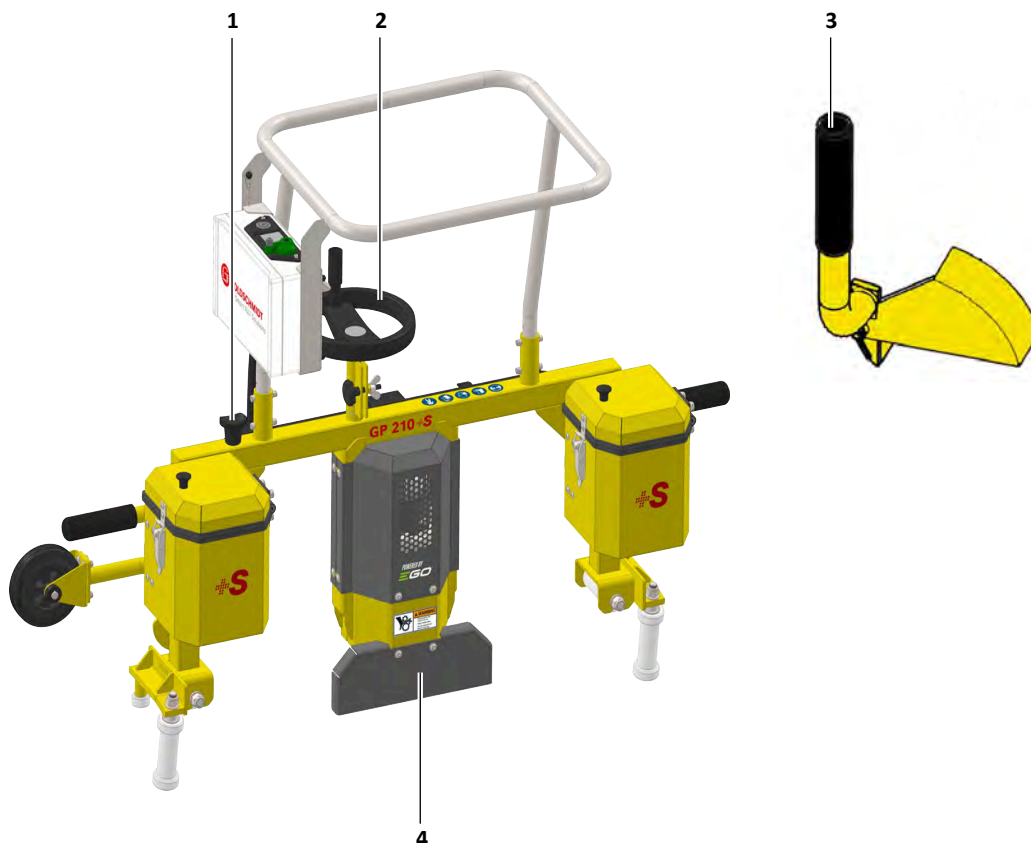

Fig. 7-1 Changing the grinding wheel

1 Locking pin
4 Guard

2 Handwheel

3 tool (stone wrench)

Ambient conditions
No special ambient conditions need to be observed.

Personnel
Specialized personnel

Tools and materials	Quantity
Grinding wheel	1
tool for loosening the grinding wheel (stone wrench)	1
Locking pin: <ul style="list-style-type: none"> • Diameter of 6 inches (15.24 cm), • Height of 3 inches (7.62 cm) and • Internal thread of 5/8"-11 UNC. • The grinding wheel must also be suitable for use at speeds of up to 3400 revolutions per minute. 	1

Maintenance 7-6 Changing the grinding wheel

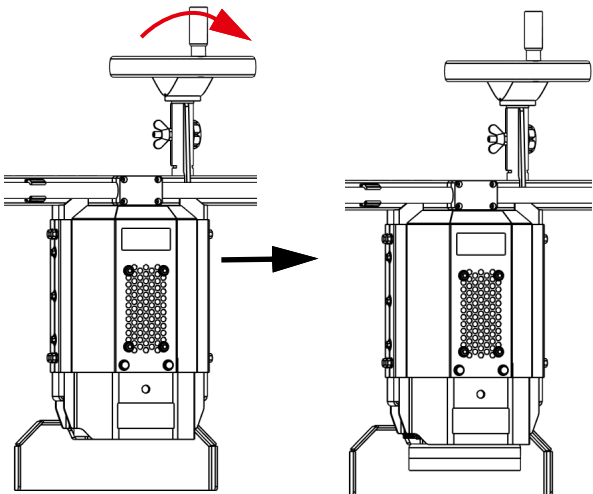
Maintenance steps	Tools / materials
<p>1. Switch off the device</p> <p>1- 001 Shut down the machine (please refer to Chapter 5 "Decommissioning (Shutdown)" on page 31).</p>	-
<p>2. Changing the grinding wheel</p> <p>2- 001 Turn the handwheel clockwise to the lower end stop.</p> 	

Maintenance 7-6 Changing the grinding wheel <continuation>

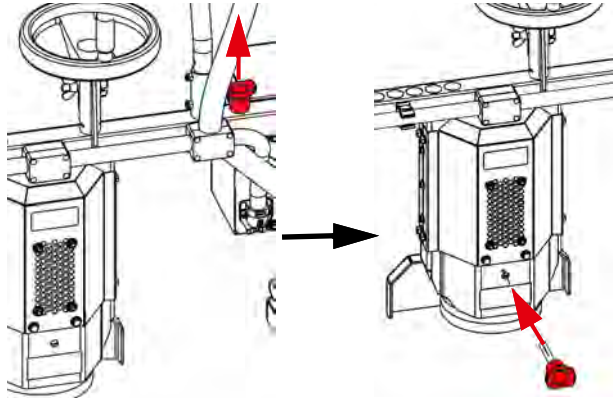
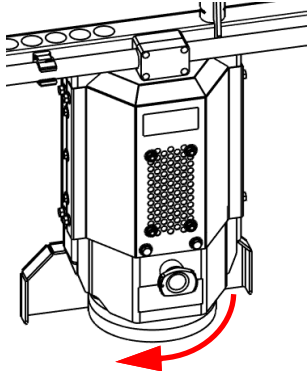
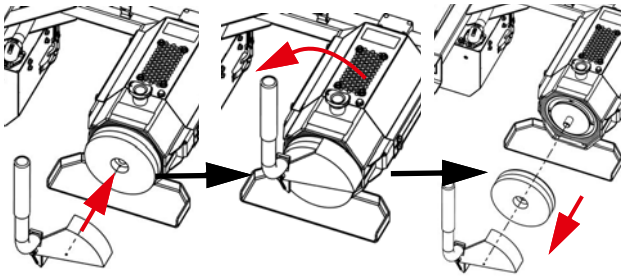
Maintenance steps	Tools / materials
<p>2- 002 Remove the locking pin from the machine frame and insert it into the holder on the drive unit.</p>  <p>2- 003 Turn the grinding wheel clockwise until the locking pin is engaged and the rotary movement blocks the grinding wheel.</p> 	<p>locking pin</p>
<p>NOTICE Always wear protective gloves when handling the grinding wheel.</p>	
<p>2- 004 Loosen the grinding wheel by turning it counter-clockwise using the tool provided.</p> 	<p>stone wrench</p>
<p>NOTICE Comply with the disposal regulations that apply in the relevant U.S. state!</p>	

Maintenance 7-6 Changing the grinding wheel <continuation>

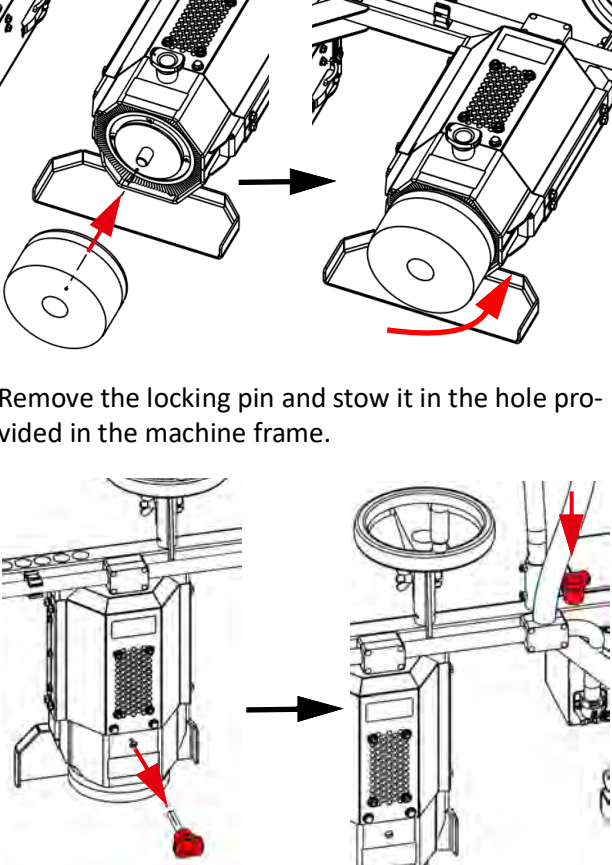
Maintenance steps	Tools / materials
<p>2- 005 Check to make sure that the shaft flange is properly seated on the spindle.</p> <p>The square on the spindle must slide into the square at the back of the shaft flange.</p> <p>If it is not properly seated, adjust it so that it is.</p> <p>2- 006 Screw the new grinding wheel onto the external thread of the grinding shaft by turning it counter-clockwise.</p>	<p>Grinding wheel</p>
<p>2- 007 Remove the locking pin and stow it in the hole provided in the machine frame.</p> 	<p>locking pin</p>

Maintenance 7-6 Changing the grinding wheel <continuation>

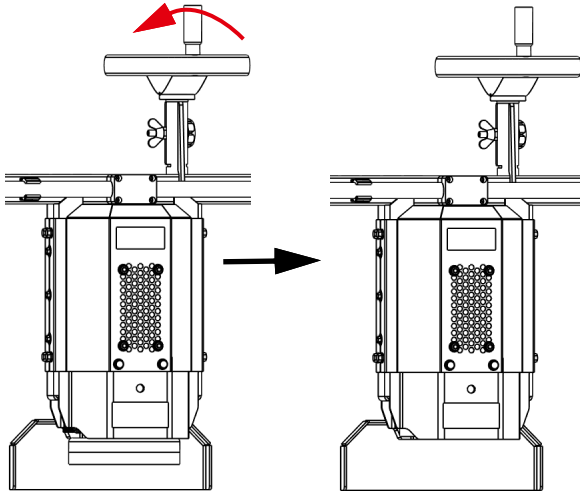
Maintenance steps	Tools / materials
<p>2- 008 Turn the handwheel counter-clockwise until the desired position of the grinding wheel is reached.</p> 	
<p>3. Switch on the device</p> <p>3- 001 Go through all the preparation steps (please refer to Chapter 3 "Commissioning" on page 19).</p>	

7.8 Checking the screw connections to make sure they are secure

Ambient conditions
No special ambient conditions need to be observed.

Personnel
Specialized personnel

Tools and materials	Quantity
Allen key to suit the screw size	-

Maintenance 7-7 Checking the screw connections to make sure they are secure

Maintenance steps	Tools / materials
1. Switch off the device	

Maintenance 7-7 Checking the screw connections to make sure they are secure <continuation>

Maintenance steps	Tools / materials
1- 001 Shut down the machine (please refer to Chapter 5 "Decommissioning (Shutdown)" on page 31).	
<p>2. Check the screw connections</p> <p>2- 001 Check all screw connections to make sure they are in place and secure.</p> <p>Replace any missing screw connections.</p>	
<p>3. Retighten the screw connections</p> <p>3- 001 Hand-tighten all screw connections by turning them clockwise using a suitable Allen key.</p>	Tool selection to suit screw type and size
<p>4. Switch on the device</p> <p>4- 001 Go through all the preparation steps (please refer to Chapter 3 "Commissioning" on page 19).</p>	

8 TRANSPORTATION AND STORAGE

Summary

Provides information and uses instructions to explain the steps required for transportation, storage, and putting the machine back into operation.

8.1 Transport of the GP 210 +S



CAUTION

RISK OF INJURY.

There is a risk of injury posed by the machine's weight. The rail head grinding machine weighs 40 kg / 88.18 lbs without grinding wheel and batteries. There is a risk of injury when the machine is being transported.

- Carrying the rail head grinding machine is mandated as a two-person job.
- Use the handles to carry the rail head grinding machine.
- Always wear safety footwear.

NOTICE

The batteries' transportation packaging must be labeled in accordance with all applicable hazardous material regulations!

NOTICE

When transporting the machine, make sure to comply with all safety and accident prevention regulations.

Follow the steps below to transport the rail head grinding machine GP 210 +S correctly:

1. Shut down the machine.

For more detailed information, please refer to Chapter 5 "Decommissioning (Shutdown)" on page 31.

2. Transport the battery-operated rail head grinding machine by hand only as far as necessary, using the handles and the transport roller.

Pull out the locking bolt and fold the transport roller down 90°.

The locking bolt engages in the nearest bracket automatically.

With the help of the handle and the and the unfolded transport roller, the battery-operated rail head grinding machine GP 210 +S can be moved.

NOTICE

If the rail head grinding machine needs to be transported across longer distances, make sure to use suitable equipment to transport it to its destination.

NOTICE

Use suitable devices to secure the machine during transportation!
Use lashing straps to secure the rail head grinding machine in such a way that it will remain upright and cannot fall over and/or be damaged.

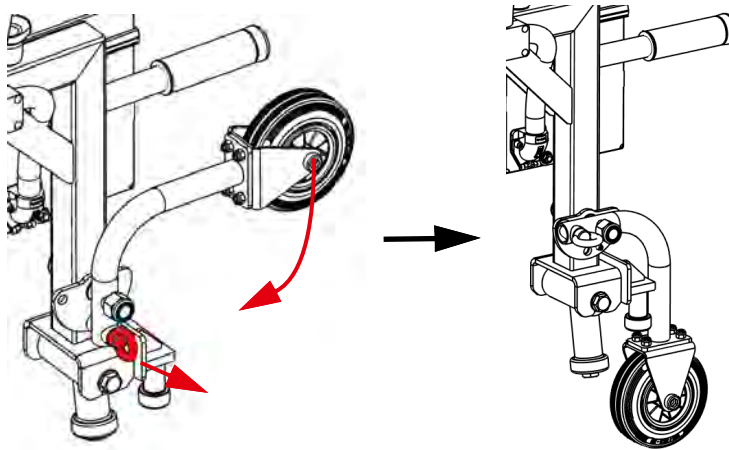

8.2 Storing the GP 210 +S

NOTICE

Storing the rail head grinding machine outdoors is strictly prohibited and will result in damage to the machine.

The following storage conditions need to be adhered to in order to properly store the machine (please refer to Table 8-1):

Storage 8-1 Storage conditions

Conditions	
Ambient conditions	- Protected from exposure to UV, - Not placed directly next to heaters or other heat sources and - Dust-free.
Storage temperature	0 °C to 40 °C (32 °F to 104 °F)
Relative humidity	40% to 60%

Follow the steps below to store the battery-operated rail head grinding machine GP 210 +S correctly:

1. Shut down the machine.

For more detailed information, please refer to Chapter 5 "Decommissioning (Shutdown)" on page 31.

2. Transport the battery-operated rail head grinding machine by hand only as far as necessary, using the handles and the transport roller.

If the rail head grinding machine needs to be transported across longer distances, make sure to use suitable equipment to transport it to its destination.

For more detailed information, please refer to Chapter 8.1 "Transport of the GP 210 +S" on page 54.

NOTICE

Use suitable devices to secure the machine during transportation!

Use lashing straps to secure the rail head grinding machine in such a way that it will remain upright and cannot fall over and/or be damaged.

3. Remove the batteries.

For more detailed information, please refer to Chapter 4.4 "Removing the batteries" on page 28.

4. Clean the battery-operated rail head grinding machine GP 210 +S.

For more detailed information, please refer to Chapter 7.4 "Cleaning the GP 210 +S" on page 41

5. Fix up any paint damage.

6. Apply a thin coating of oil to any areas that could rust.

7. Properly store the battery-operated rail head grinding machine GP 210 +S at the corresponding storage location.

NOTICE

Store the rail head grinding machine on pallets or shelves (not directly on the floor or against walls) in order to prevent the ingress of moisture.

NOTICE

Store the rail head grinding machine upright.

NOTICE

If necessary, use a protective cover/dust cover to protect internal parts from soiling and other impurities.

8.3 Putting the GP 210 +S back into operation

Follow the steps below in order to put the machine back into operation:

1. Remove the GP 210 +S from its storage location.
2. If you used a protective cover or dust cover, remove it.
3. Transport the GP 210 +S to the place where it will be used.

For more detailed information, please refer to Chapter 8.1 "Transport of the GP 210 +S" on page 54.

4. Insert the batteries.

For more detailed information, please refer to Chapter 4.1 "Inserting the batteries" on page 22.

5. Go through all the preparation steps.

For more detailed information, please refer to Chapter 3 "Commissioning" on page 19.

9 DISPOSAL

Summary

How to properly dispose of the GP 210 +S and its components and/or accessories.

NOTICE

Comply with the disposal regulations that apply in the relevant U.S. state!

NOTICE

At the end of its service life, the rail head grinding machine must be separated from unsorted municipal waste and properly disposed of in compliance with all applicable national and international legislation and regulations.

NOTICE

The machine must be disposed of exclusively by trained specialized personnel or by specialized companies that have been tasked with this disposal.

Next Steps

1. Shut down the machine (please refer to Chapter 5 "Decommissioning (Shutdown)" on page 31).
2. Remove the batteries (EGO Power+ 56V-ARC-Lithium™) from the GP 210 +S (please refer to Chapter 4.4 "Removing the batteries" on page 28).

NOTICE

Follow EGO's disposal instructions (please refer to Chapter 1.4 "Further applicable documents" on page 4).

3. Dispose of the rail head grinding machine at an authorized recycling facility.

NOTICE

Comply with the disposal regulations that apply in the relevant U.S. state!

10 CUSTOMER SERVICE

Summary

Contact information for the manufacturer in the event that you need to get in touch in order to buy spare parts, return an old machine, or get a problem fixed.

10.1 Contact details

You can find the contact information in Table 10-1 below:

Tab. 10-1 Contact details

Address	ELEKTRO-THERMIT GMBH & CO.KG A GOLDSCHMIDT COMPANY Chemiestraße 24 06132 Halle (Saale)
Phone	+49 345 7795-600
Fax	+49 345 7795-770
e-mail	et@goldschmidt.com
Internet	www.goldschmidt.com

ANNEX A - TECHNICAL DATA

NOTICE

For more technical data about supplier components, refer to Chapter 1.4 "Further applicable documents" on page 4.

Tab. A-1 General data

General data	
Manufacturer	ELEKTRO-THERMIT GMBH & CO.KG A GOLDSCHMIDT COMPANY Chemiestraße 24 06132 Halle (Saale)
Device information	
Designation	battery-operated rail head grinding machine GP 210 +S
Serial number	from GP 210 +S-0001
Year of manufacture	from 2025

Tab. A-2 Technical data

Technical data	
Measures and weights	
Length	1274 mm / 50.15 inches
Height (min.)	996 mm / 39.21 inches
Width	459 mm / 18 inches
Weight (without grinding wheel and rechargeable battery)	40 kg / 88.18 lbs
Torque (max.)	9 Nm
Performance (max.)	3.3 kW / 4.49 HP
Drive	
Quantity	2
Type of battery	EGO Power+ 56V-ARC-Lithium™
Battery potential	56 V
Battery capacity	12 Ah
Motor speed	3400 rpm
Temperature ranges /Operating conditions	

Tab. A-2 Technical data <continuation>

Technical data	
Ambient temperature when operating the machine	-20 °C to +40 °C (-4 °F to +104 °F)
Ambient temperature when charging the batteries	+5 °C to +40 °C (+41 °F to +104 °F)
Ambient temperature while in storage	0 °C to 40 °C (32 °F to 104 °F)
stone wrench (tool for loosening the grinding wheel)	
Weight	1,1 kg / 2.5 lb
Dimensions (L x W x H)	356 mm x 165 mm x 114 mm / 14 in x 6.5 in x 4.4 in

Tab. A-3 Emissions

Emissions	
In technically perfect condition, the A-assessed emission level at the workplace is > 70 dB(A) during the grinding process. It is mandatory to wear ear defenders approved for use in the rail sector.	
Sound pressure level	67 dB(A)
Sound pressure level (grinding)	87 dB(A)
Noise level (idle state)	82 dB(A)
Noise level (grinding)	102 dB(A)
Hand-arm vibration (grinding), measured at the handles	2.0 m/s ²

**CAUTION****HEARING LOSS.**

Noise levels during grinding may result in permanent hearing loss. Make sure to always wear hearing protection. Individuals who are not working with or on the grinding machine must stay at a minimum distance of 1.5 m / 59 inches. Agree on clear and effective hand signals for communication.

ANNEX C - DECLARATION OF CONFORMITY

TRANSLATION OF THE ORIGINAL DECLARATION

EC Declaration of Conformity

in accordance with EC Machinery Directive 2006/42/EG, Appendix II, No. 1 A

The manufacturer:

ELEKTRO-THERMIT GMBH & CO. KG

Chemiestr. 24

06132 Halle (Saale)

hereby declares that the following product

Trade designation: Battery Rail Head Grinding Machine

Product name: GP 210 +S

Serial number: GP210+S-XXXX (XXXX sequential number)

corresponds to all relevant provisions of EC Machinery Directive 2006/42/EC Appendix I.

Related harmonized standards
EN ISO 12100: 2011-03 Safety of machinery - General principles for design - Risk assessment and risk reduction
EN 13977:2011-04 Safety requirements for portable machinery and trolleys for construction and maintenance
ISO 3744:2010-10 Acoustics - Determination of sound power levels and sound energy levels of noise sources from sound pressure measurements [...]
ISO 11201:2010-10 Acoustics - Noise emission from machinery and equipment - Determination of emission sound pressure levels at workplaces [...]
EN ISO 5349-1:2001-12 Mechanical vibration - Measurement and evaluation of human exposure to hand-arm vibration - Part 1: General requirements
EN 61000-6-2:2019-11 Electromagnetic compatibility (EMC) - Part 6-2: Generic standards - Immunity for industrial environments
EN 61000-6-4:2020-09 Electromagnetic compatibility (EMC) - Part 6-4: Generic standards - Emission standard for industrial environments

Mr. Sven Kummer, Am Schenkberg 20, 04349 Leipzig, Germany, is authorized to submit the technical documents.

Halle (Saale), 30.04.2025

Dr. Axel Hoeschen
Managing Director

ANNEX D - ACCESSORIES

When ordering accessories, you will need to provide your GP 210 +S's model and serial number. You can find this information on the rating plate (please refer to Chapter 2.4.1 "Rating plate" on page 8).

Tab. D-1 Accessories

Accessory	Quantity
EGO Power+ 56V-ARC-Lithium™ (12 Ah)	2
Air filter	1
Grinding wheel	1

LIST OF FIGURES

Fig. 2-1	Main sub-assemblies GP 210 +S.....	8
Fig. 2-2	Rating plate.....	9
Fig. 2-3	LED display	10
Fig. 2-4	Key switch	10
Fig. 2-5	Control lever	11
Fig. 2-6	LED display – speed.....	12
Fig. 2-7	Safety label (frame.....	13
Fig. 2-8	Safety label (drive unit).....	14
Fig. 2-9	Safety systems	15
Fig. 2-10	LED display – battery charge status	17
Fig. 7-1	Changing the grinding wheel	48
Fig. A-1	General drawings	III

LIST OF TABLES

Tab. 1-1	Qualification level	3
Tab. 1-2	Personal protection equipment	3
Tab. 1-3	Additional applicable documents – supplier documentation	4
Tab. 1-4	Additional applicable documents – manufacturer documentation	4
Tab. 1-5	Scope of delivery.....	5
Tab. 2-1	Operating conditions GP 210 +S	7
Tab. 2-2	Coloring GP 210 +S	12
Tab. 2-3	Battery LED indicator modes	16
Tab. 7-1	Maintenance schedule	39
Tab. 10-1	Contact details	59
Tab. A-1	General data	I
Tab. A-2	Technical data	I
Tab. A-3	Emissions	II
Tab. D-1	Accessories	V

INDEX**A**

Abbreviations	xi
Accessories	
Rechargeable battery	16
Accessory	V
Accessory devices	16
Additional applicable documents	4
Adjusting the speed	27
Ambient temperature	7, II

B

Battery	
Battery bracket	23, 29, 34
Charger	18
Flat	32
Overheated	17, 33
Removal	28
Battery charge level	32

C

Changing the filter	45
Changing the grinding wheel	39
Charge status	16
Charger	18
Type	18
Checking of screw connections	39
Cleaning the air filter	39, 42, 45
Cleaning the filter	42
Coloring	12
golden yellow	12
gray aluminum	12
jet black	12
traffic gray	12
Coloured marking	12
Commissioning	19
Construction description	6
Contact details	59
Control lever	11
Customer Service	59
contact details	59
e-mail	59
Fax	59
Telephone	59
Website	59
Customer service	59

D

Declaration of conformity	IV
Decommissioning	31
Defect	32

Device information	I
Dimensions	I
Disposal	58
Drive	I

E

Emergency	15
Error code	35

F

Fault, cause and elimination	32
Fire extinguisher	15
Function description	6
Functional test	20
Further applicable documents	4

G

General drawings	III
Glossary	xii
Grinding	24

H

Hand-arm vibration	II
History of Changes	iii
Humidity	55

I

Intended use	6
Introduction	1
Information about this document	1
Requirements for operators	1
Validity	1

L

LED-Display	9
List of accessories	V
List of figures	VI
List of tables	VII

M

Main sub-assemblies	7
Maintenance	
Cleaning	39
Maintenance and care	37
Changing the grinding wheel	48
Cleaning	39, 41
Maintenance schedule	39
Visual inspection	39
Visual inspection of safety labels	40
Maintenance schedule	39
Cleaning	39
Inspection of rating plate	39

Inspection of safety label	39	T	
Maintenance task	39		
Mandatory and warning signs	13	Technical data	I
Manufacturer	I	Torque value	I
Modes		Transport	54
Charge status	16	Troubleshooting	32
Motor speed	I	Type	I
O		U	
Operating conditions	7, I	Use	6
Operation	22	V	
Operator		Validity	1
Occupation	3	Visual inspection	39
Personal protection equipment (PPE)	3	Visual inspection and condition check	39
Qualification	1	W	
Qualification level	2	Website	59
Requirement	1	Weight	I
Operator control and display elements	9	Y	
Operators		Year of manufacture	I
Requirements	1		
P			
Pictograms	xii		
R			
Rating	I		
Rating plate	8		
Rechargeable battery	16		
Capacity	I		
Charge status modes	16		
Low voltage	17		
Type	I		
Rechargeable battery LED	16		
Recommissioning	56		
Requirement	1		
S			
Safety instructions			
Explanations	iv		
general	x		
Safety labels	12		
Safety systems	14		
Schlüsselschalter	10		
Scope of delivery	5		
Serial number	9, I		
Sound power level	II		
Sound pressure level	II		
Spare parts	V		
stone wrench	II		
Storage	55		
conditions	55		
environmental conditions	55		
Symbols	xii		