

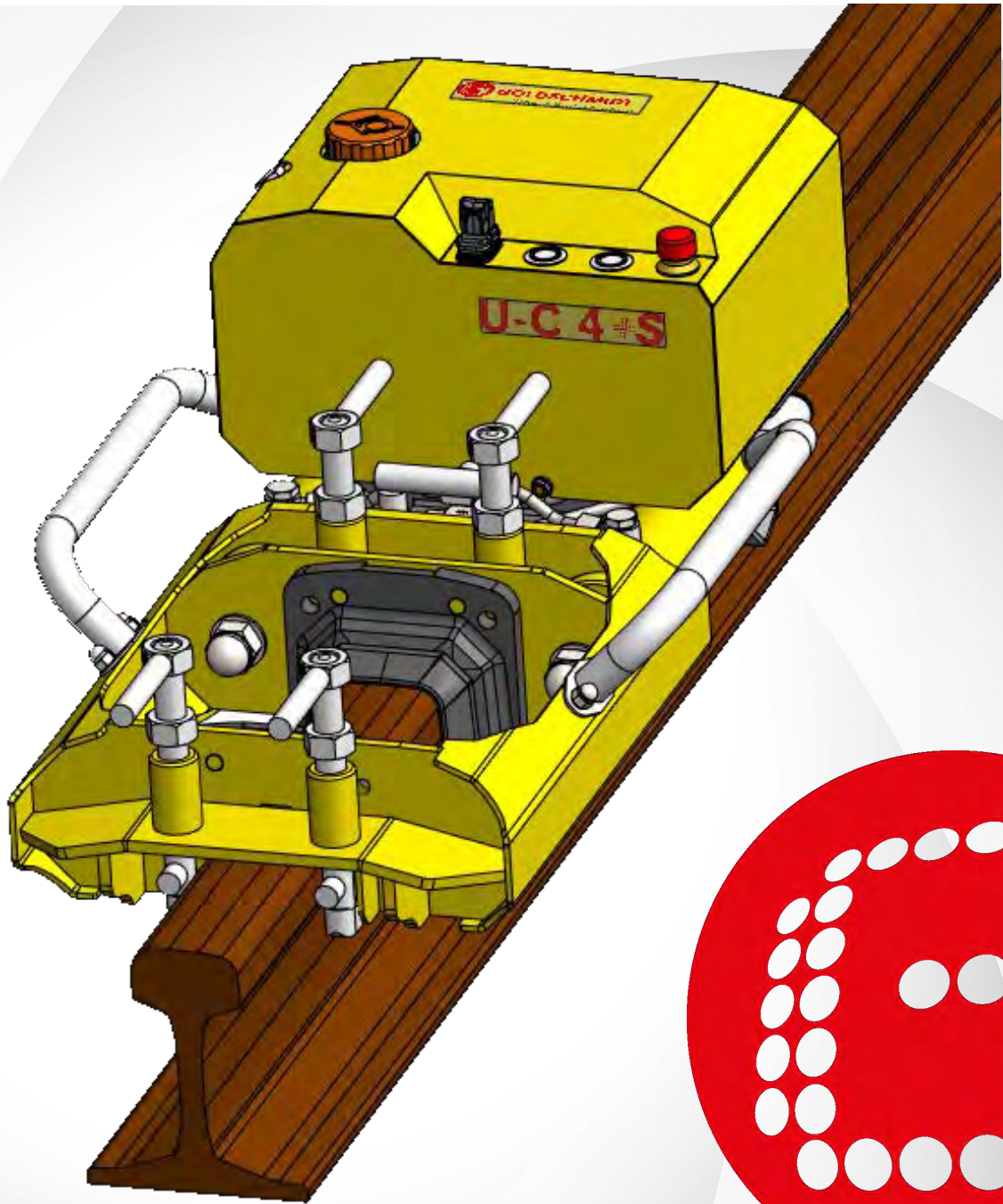

GOLDSCHMIDT

Smart Rail Solutions



U-C4 +S
WELD SHEAR

TRANSLATION OF ORIGIN

Copyright: ©Elektro-Thermit GmbH & Co. KG

All Rights Reserved

This manual was produced by Elektro-Thermit GmbH & Co. KG. The applicable copyrights must be observed. Without the prior written approval of Elektro-Thermit GmbH & Co. KG, it is prohibited to reproduce, amend and translate this document, either wholly or in part.

Publisher:

Elektro-Thermit GmbH & Co. KG

Chemiestraße 24

06132 Halle (Saale), Germany

Phone: +49 345 7795-600

Fax: +49 345 7795-770

e-mail: et@goldschmidt.com

Internet: www.goldschmidt.com

Document: manual U-C4 +S (Weld shear)

Version: 2.0 (translation of origin)

valid from serial number: U-C4+S-0010

Year of manufacture: 2026 or later

Country of origin: Germany

Trademark use

The names of companies and products used in this manual may be registered trademarks of their respective owners.

HISTORY OF CHANGES

Version	Date	Change / Description	Author	Approved by
0.0	2023-10-11	Initial issue	Goldschmidt Holding GmbH	Elektro-Thermit GmbH & Co. KG
1.0	2025-04-30	Revised manual structure	Goldschmidt Holding GmbH	Elektro-Thermit GmbH & Co. KG
2.0	2026-03-13	Added emissions, new rating plate – applicable starting with serial number U-C4+S-0010	Goldschmidt Holding GmbH	Elektro-Thermit GmbH & Co. KG

STRUCTURE AND CONTENT OF SAFETY INSTRUCTIONS

This manual contains safety instructions that point out potential hazards and risks that could result in personal injury, property damage, and/or environmental damage. The way these safety instructions are structured, as well as their contents, is based on the ANSI Z535 standard.

Safety instructions related to personal injury



DANGER indicates a hazardous situation that, if not avoided, will result in death or serious injury.



WARNING indicates a hazardous situation that, if not avoided, could result in death or serious injury.



CAUTION indicates a hazardous situation that, if not avoided, could result in minor or moderate injury.

The contents of all safety instructions related to personal injury have been structured in conformity with the German SAFE method:

SIGNAL WORD/ SYMBOL

S – Schlagwort (keyword)

A - Art und Quelle der Gefahr (type and source of hazard)

F - Folgen bei Nichtbeachtung (consequence of failure to observe the instruction)

E - Entkommen (how to avoid the hazard)

Safety instructions related to property damage and the environment



NOTICE (white text on a blue background) indicates potential property damage.



NOTICE (black text on a green background) indicates potential environmental damage.

General notes



NOTICE (black text on a white background) indicates general information that needs to be taken into account when handling the product.

This manual has safety instructions at various points in order to ensure that meaningful information is provided in regard to potential hazard sources:

- Introductory safety instructions (at the beginning of the document)
- Section-specific safety instructions (at the beginning of a section)
- Embedded safety instructions (for specific instructions).

SAFETY INSTRUCTIONS

Safety instructions related to personal injury



RISK OF INJURY.

There is a risk of injury due to fire and/or explosion.
The machine must not be operated in an environment where there is a risk of fire or explosion nor in the vicinity of flammable or explosive liquids or gases.



RISK OF INJURY.

The U-C4 +S Weld shear weighs a total of 45 kg / 99 lbs. Having a single person attempt to carry it by themselves may result in injury.
Make sure to always use two people to set the U-C4 +S down in place and lift it off.

Safety instructions related to property damage

NOTICE

Make sure that there are no highly flammable or explosive substances in the vicinity. If necessary, remove any combustible substances from the work area and ensure that there is adequate ventilation.

NOTICE

Do not, under any circumstance, open threaded joints marked in colour.

NOTICE

Do not place the Weld shear in water or hose it down.

NOTICE

Genuine spare parts and/or accessories authorized by the manufacturer help ensure safety.
Using any other accessories will void our liability for resulting damages.
The manufacturer hereby disclaims all liability for any components retrofitted by the operating company.

NOTICE

Alterations, repairs, and modifications require the manufacturer's explicit approval.

NOTICE

Make sure to keep all safety labels in legible condition! If safety labels are damaged or go missing at any point in the machine's service life, the operating company must ensure that they are replaced properly.

NOTICE

The manual U-C4 +S must be read carefully before starting any operation, assembly, installation, and/or maintenance work!

NOTICE

A hard copy of the manual U-C4 +S must be available in legible condition at the location of use.

NOTICE

In addition to the information and instructions in this manual, all applicable accident prevention regulations and environmental and occupational health and safety regulations must be complied with. Moreover, all of the operating company's accident prevention rules and policies must be followed.

All safety requirements set forth by the applicable rail authorities for work on tracks and in the vicinity of tracks must be followed without fail.

Safety instructions related to the environment

Environmentally hazardous substances must be properly disposed of in compliance with all applicable requirements and regulations. Make sure to observe the manufacturer's data sheets and safety data sheets.

For more detailed information, please refer to Chapter 9 "Disposal" on page 44.

NOTICE

Properly dispose of all packaging material.

For more detailed information, please refer to Chapter 9 "Disposal" on page 44.

NOTICE

Please refer to Chapter 9.1 "Waste code numbers (WCN) in the EU" on page 45 for waste code numbers.

RESIDUAL RISK WARNING

All the components in the U-C4 +S weld shear have been designed in line with the state of the art. Regardless of this, however, their use may pose hazards to the operator and to third parties, the environment, and/or other equipment. Accordingly, the Weld shear U-C4 +S may only be used in a proper working condition. Moreover, it must always be used in conformity with all applicable safety rules and regulations and the Operation manual U-C4 +S.

Risk of workplace injury

Welding and shearing work both take place in work environments where it is possible for welding and other work to be in progress at the same time and in the immediate area. Accordingly, there is a higher risk of injury due to scenarios including, but not limited to:

- Rail traffic on adjacent tracks
- Being struck or run over by construction vehicles
- Getting caught or entrapped in construction vehicles or other moving machinery
- Slipping on slippery, wet, or oily surfaces
- Tripping on obstacles
- Falling onto pointed or sharp objects
- Burns due to hot surfaces

Make sure to take the following precautions:

- Observe all work site rules
- Make sure that there is nobody else within the shearing unit's danger zone
- Make sure to work only if there is adequate lighting
- Be careful and alert at all times
- Make sure that there is adequate ventilation
- Do not, under any circumstance, leave the running drive unit unsupervised

ABBREVIATIONS

Units of measurement	
%	Percent
°C	Degrees Celcius
°F	Degrees Fahrenheit
Ah	Ampere-hour
cST	Centistokes (1 cSt = 1 mm ² /s)
dB (A)	Decibels at a specific measuring distance
gal	Gallon
hp	Horsepower (1 hp = 745.70 W)
in	inch
kg	Kilogram
kN	Kilonewton
kW	Kilowatts
L	Liter
L/min	Liters per minute
lbs	pound
mm	Millimeters
rpm	Revolutions per minute
V	Volts

General	
e.g.	for example
max	maximum
min	minimum

GLOSSARY

Symbols and pictograms

Symbol	Explanation
	Crush hazard warning
	Read and follow the manual
	Wear safety eyewear
	Wear work gloves
	Wear protective clothing
	Wear safety footwear

CONTENT

History of Changes.....	iii
Structure and Content of safety instructions	iv
Safety instructions	v
Residual risk warning.....	vii
Abbreviations	viii
Glossary	ix

CHAPTER 1: INTRODUCTION

1.1 Information about this document.....	1
1.2 Validity	1
1.3 Requirements for operators	1
1.3.1 Skills	1
1.3.2 Qualification levels.....	2
1.3.3 Personal protection equipment.....	3
1.4 Further applicable documents	4

CHAPTER 2: CONSTRUCTION DESCRIPTION

2.1 Function description	5
2.2 Intended use	5
2.3 Operating conditions.....	5
2.4 Main sub-assemblies.....	6
2.4.1 Shear blades	8
2.4.2 Guide shoe	8
2.4.3 Rating plate.....	9
2.5 Operator control and display elements	10
2.5.1 Joystick.....	10
2.6 Colours and safety labels	11
2.6.1 Colouring.....	11
2.6.2 Safety labels	11
2.7 Safety systems.....	12
2.8 What to do in case of emergency	13
2.9 Accessory devices.....	13
2.9.1 Rechargeable battery.....	13
2.9.2 Charger.....	14

CHAPTER 3: COMMISSIONING

3.1 Test run	16
--------------------	----

CHAPTER 4: OPERATION

4.1 Inserting the batteries.....	19
4.2 Refilling hydraulic oil	20
4.3 Carrying out a shearing operation	21
4.4 Draining hydraulic oil	24
4.5 Removing the batteries.....	25
4.6 Mounting the shear blades	26
4.7 Removing the shear blades.....	26

CHAPTER 5: DECOMMISSIONING**CHAPTER 6: FAULT, CAUSE AND ELIMINATION****CHAPTER 7: MAINTENANCE AND CARE**

7.1	Maintenance schedule	33
7.2	Visual inspection of the U-C4 +S	33
7.3	Cleaning the U-C4 +S.....	34
7.4	Oil level check	35
7.5	Checking for leaks	36
7.6	Visual inspection and condition check Safety labels and rating plate	37
7.7	Changing the hydraulic oil.....	38
7.8	Removing burrs and offsets	39
7.9	Regrinding the Shear blades	40

CHAPTER 8: TRANSPORT AND STORAGE

8.1	Transporting the U-C4 +S	42
8.2	Storing the U-C4 +S	42
8.3	Putting the U-C4 +S back into operation.....	43

CHAPTER 9: DISPOSAL

9.1	Waste code numbers (WCN) in the EU	45
-----	--	----

CHAPTER 10: CUSTOMER SERVICE

10.1	Contact details	46
Annex A - Technical data		I
Annex B - General drawings		III
Annex C - Declaration of Conformity.....		IV
Annex D - Accessories.....		V
List of figures		VI
List of tables		VII
Index		VIII

1 INTRODUCTION

Summary

This section provides information regarding the scope and content of this manual, as well as references to additional documents.

1.1 Information about this document

This manual describes how the U-C4 +S weld shear works and its components.

This manual must be:

- Considered part of the product,
- Stored safely throughout the product's entire service life,
- Passed on to any subsequent users.

1.2 Validity

This manual (version 2.0 (translation of origin)) is meant for the following machine configuration:

- Weld shear U-C4 +S valid starting with serial number U-C4+S-0010.

1.3 Requirements for operators

The operators who will be using the U-C4 +S must:

- Be at least 18 years old,
- Have the required qualifications for the job,
- Have received training regarding how to operate the machine properly,
- Have passed a medical assessment of fitness for work.

NOTICE

All applicable accident prevention regulations must be complied with without fail. Moreover, all operation and maintenance manuals must be followed without exception.

NOTICE

The operating company must make sure that its operating personnel has fully understood the Operation manual U-C4 +S's contents.

1.3.1 Skills

Only individuals who meet the following requirements are allowed to work with and on the machine:

- Operators must have read and understood this manual in its entirety.
- Operators must be in perfect health and in full possession of their mental and physical faculties.

- Operators must be rested and must not be under the influence of any drugs, alcohol, or medications that could have a negative impact on their ability to react to situations and absorb information.
- Operators must be regularly briefed on impediments, hazards, fire safety rules, and special rules regarding what to do and what not to do.
- Operators must wear all required personal protection equipment in order to ensure that all occupational health and safety requirements are met.
- Operators must always observe their employer's rules and policies regarding safety and accident prevention and comply with all regulations that are relevant to personal safety and the safety of third parties.

1.3.2 Qualification levels

In order to ensure that the machine will be operated safely and as intended, two different qualification levels must be considered:

- Operating personnel:

Is trained on how to regularly operate the machine, receives continuous training regarding technical innovations, and has the required basic skills and understanding needed to work with the U-C4 +S Weld shear.

During their initial training session, operators must receive training regarding the following main points:

- Function description,
 - An explanation of the individual components
 - An explanation of potential hazards
 - How to use the machine
 - How to identify malfunctions and other issues
- Maintenance personnel/specialized personnel:

Personnel that has received special training and briefing intended specifically for maintenance, servicing, and/or repair work on the machine.

Table 1-1 on page 2 lists the various individual tasks that apply to each of the two qualification levels.

Tab. 1-1 Qualification level

Occupation	Qualification level	
	Operating personnel	Maintenance/specialized personnel
Working with the machine, operating the machine	x	x
Cleaning the machine	x	x



Tab. 1-1 Qualification level <continued>

Occupation	Qualification level	
	Operating personnel	Maintenance/specialized personnel
Visual inspection	x	x
Identifying malfunctions and other issues	x	x
Maintenance work		x
Troubleshooting and repairs		x

1.3.3 Personal protection equipment

Provided that the operating company does not set forth any additional rules, policies, or guidelines, the following protection equipment must be worn when working with or on the machine:

Tab. 1-2 Personal protection equipment

Symbol	Protection equipment	Use
	Wear safety footwear (high-top S3 safety footwear in conformity with EN ISO 20345)	<ul style="list-style-type: none"> • Transport, • Commissioning, • Operation, • Decommissioning, • Maintenance and • Cleaning and maintenance.
	Wear work gloves (heavy-duty gloves in conformity with EN 388 (4242), EN 402; if necessary, heat-resistant work gloves in conformity with EN 407)	
	Wear protective clothing Welding clothing in conformity with EN 470-1; if necessary, high-visibility clothing in conformity with EN 471	

Tab. 1-2 Personal protection equipment <continued>

Symbol	Protection equipment	Use
	Wear safety eyewear	- Operation (shearing)

1.4 Further applicable documents

NOTICE

Passing the Operation manual U-C4 +S on to third parties requires written consent from Elektro-Thermit GmbH & Co. KG.

NOTICE

The manufacturer's technical documentation is protected by copyright.

NOTICE

In addition to the information and instructions in this manual, all applicable accident prevention regulations and environmental regulations must be complied with.

Compliance is also required with the safety regulations issued by the railway authorities for working on and near the tracks.

Additional applicable documents are listed in the tables below and are an integral part of the included contents:

Tab. 1-3 Additional applicable documents – supplier documentation

Technical documentation (supplier documentation)
manual for EGO Power+ 56V-ARC-Lithium™ battery [EGO]

Tab. 1-4 Additional applicable documents – manufacturer documentation

Technical documentation (manufacturer documentation)
Work instructions for the relevant Thermit® welding process

2 CONSTRUCTION DESCRIPTION

Summary

An overview of the U-C4 +S, the names of the various sub-assemblies and components, and what they do.

NOTICE

Unauthorized alterations are impermissible.
The manufacturer hereby disclaims all liability for any resulting personal injury and/or damages to machinery and other property.

NOTICE

The manufacturer hereby disclaims all liability for any improper or unintended use and any resulting injury and/or damages.

NOTICE

Any other use of the U-C4 +S, including any use that extends beyond the intended use, is impermissible.

2.1 Function description

The Weld shear features a guide frame, two hydraulic cylinders, a shearing support beam, four guide shoes, a 4/3 control valve, and a battery.

The Weld shear is fitted with two adapted on the rail profile, exchangeable shear blades that are moved on top of each other by two hydraulic cylinders arranged in parallel, enabling weld superantants to be shorn off on both sides. It is controlled with a 4/3 control valve.

2.2 Intended use

The U-C4 +S Weld shear is intended for removing excess weld metal after Thermit® welding on flat-bottom rails. The Shear blades can be changed as necessary.

The Weld shear is designed to be operated by a single person. However, two people are needed in order to set it down on and lift it off from the intended track.

2.3 Operating conditions

NOTICE

Do not, under any circumstance, operate the machine if actual conditions differ from these operating conditions.

Table 2-1 on page 5 describes the operating conditions in greater detail:

Tab. 2-1 Operating conditions U-C4 +S

Operating conditions	
Ambient temperature when operating the machine	-10 °C to +40 °C (14 °F to 104 °F)
Ambient temperature when charging the batteries	+5 °C to +40 °C (41 °F to 104 °F)
Minimum oil temperature	+10 °C / 50 °F

Also, the following conditions need to be satisfied when operating the machine:

- It is strictly prohibited to defeat or otherwise disable guards, safety devices, and other components.
- Do not operate the machine if it is not in proper working condition.
- All inspection and maintenance intervals must be observed.
- The machine must not be operated in an environment where there is a risk of fire or explosion nor in the vicinity of flammable or explosive liquids or gases.
- The workplace must be illuminated sufficiently to enable potential danger areas to be detected in good time.

2.4 Main sub-assemblies

Figure 2-1 on page 7 shows the main sub-assemblies on the U-C4 +S.

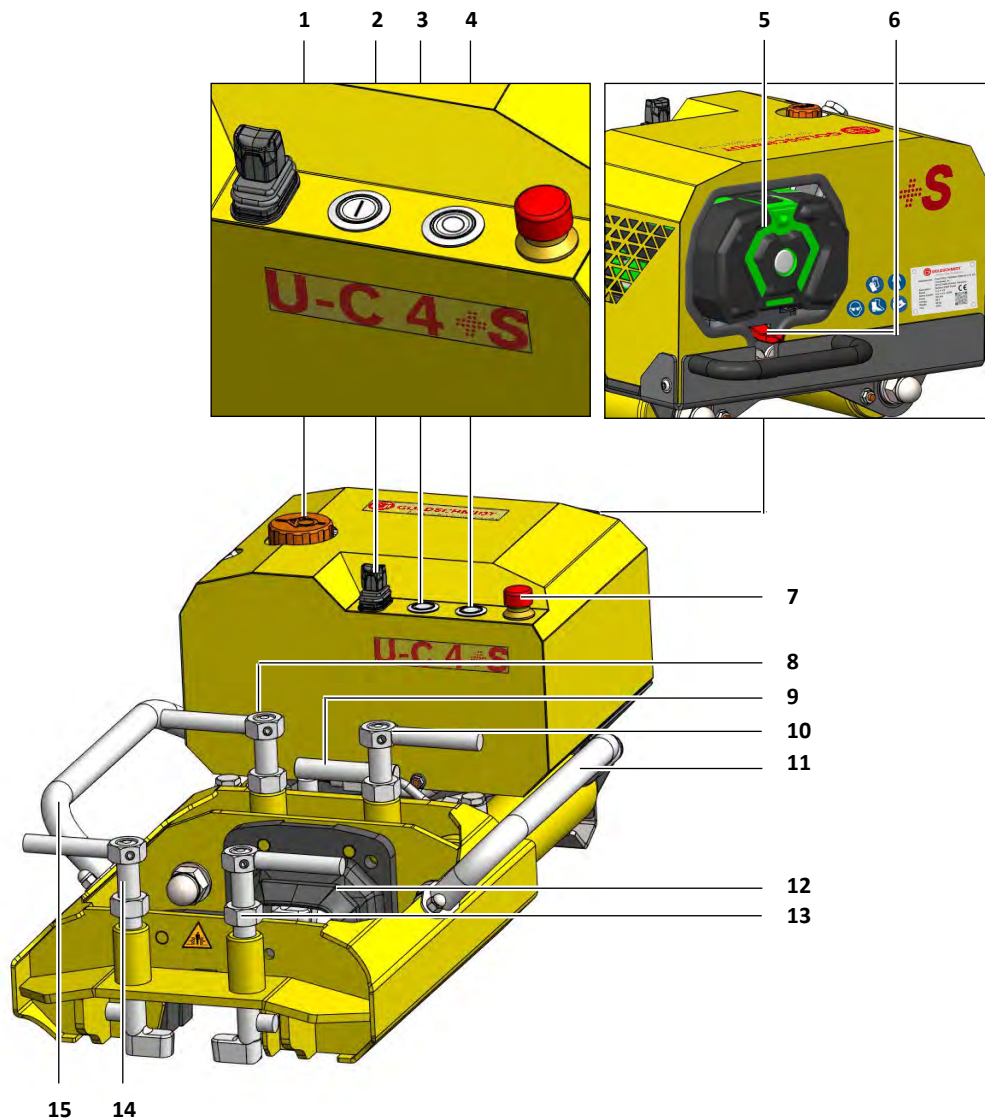

Fig. 2-1 Main sub-assemblies U-C4 +S

1 Oil filler / oil drain plug	6 Locking tab (battery compartment)	11 Carrying handle
2 Joystick	7 Emergency-stop button	12 Shear blade (two)
3 ON button	8 Guide shoe	13 Guide shoe
4 OFF button	9 Fork	14 Guide shoe
5 Battery compartment	10 Guide shoe	15 Carrying handle

The ON button and OFF button buttons are illuminated pushbuttons and have the following modes (please refer to Table 2-2 on page 7).

Tab. 2-2 Modes ON button/OFF button

Modes	Description
Green (continuous light)	The Weld shear is on. The ON button and the OFF button both light up with a solid green light.

Tab. 2-2 Modes ON button/OFF button <continued>

Modes	Description
Green flashing	The OFF button flashes green when you press the ON button. The Joystick is not in its center position and is preventing the Weld shear from being turned on.
Red (continuous light)	The Weld shear is on and there is a fault.
Off	The Weld shear is off.

2.4.1 Shear blades

NOTICE

It is extremely important to observe the shearing times specified in the work instructions!

A "cold shearing" leads to destruction of the cutters on the shear blades.

Each shear blade type is designed for a specific rail profile and features cutting edges made of wear-resistant, high-temperature steel.



Fig. 2-2 Shear bladetype A - flat-bottom rails

2.4.2 Guide shoe

The Weld shear U-C4 +S features four Guide shoes. These guide shoes ensure that the Weld shear will lay on the track properly and will enclose the rail head during shearing. The guide shoes are operated manually by the operator.

The guide shoes can assume the following positions:

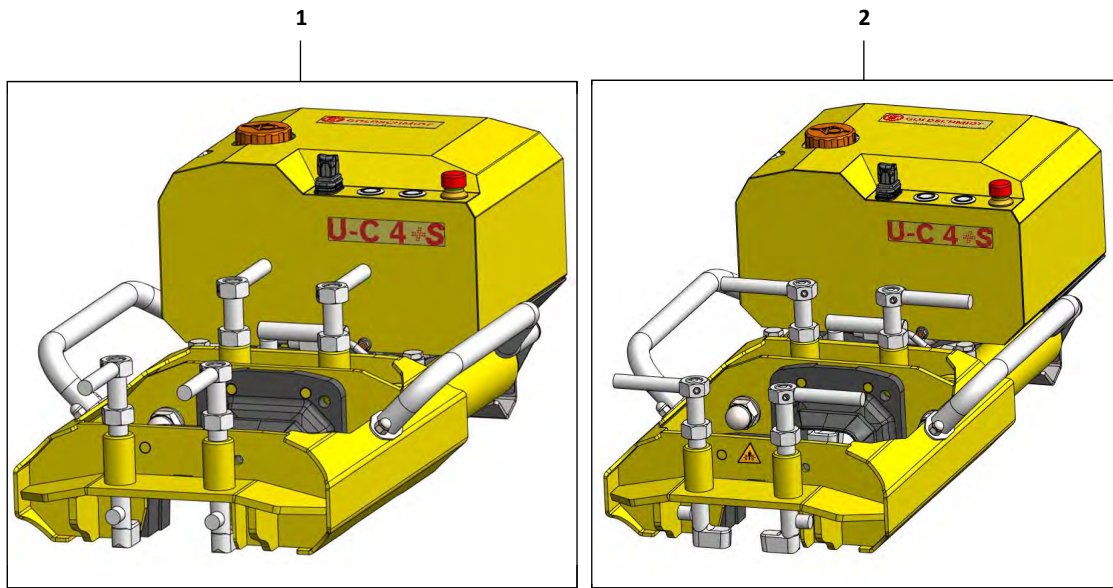

Fig. 2-3 Guide shoe positions

Position	Description
1 Transport position	When in the transport position, the Guide shoes are parallel to the frame. This means that the Clamping jaw on the Guide shoes will be pointing away from the track. This transport position is used whenever the Weld shear is being set down on or lifted off from a track.
2 Operating position	When in the operating position, the Guide shoes are parallel to the carrying handles. The Clamping jaw on the Guide shoes will be resting against the track. This operating position is used for the actual shearing operation.

2.4.3 Rating plate

The rating plate can be found at the back of the U-C4 +S (please refer to Figure 2-4 on page 9).

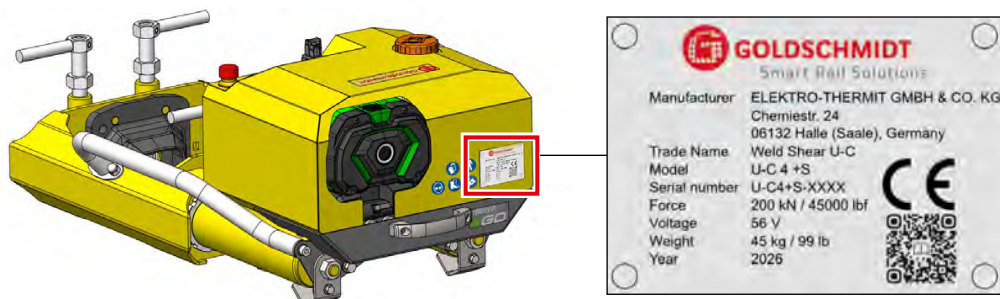

Fig. 2-4 Rating plate

The rating plate contains the following information:

- Manufacturer information,
- Product name,
- Product model,
- Serial number,

- Voltage,
- Tare weight,
- Year of manufacture,
- CE marking and
- QR code for the manual

NOTICE The operating company must make sure that the rating plate is replaced if it becomes damaged or goes missing.

2.5 Operator control and display elements

2.5.1 Joystick

The Shear blades can be controlled with the integrated Joystick.

The Joystick features maintained end positions.



Fig. 2-5 Joystick

The joystick can be used to carry out the following actions (please refer to Table 2-3 on page 10):

Tab. 2-3 Position Joystick

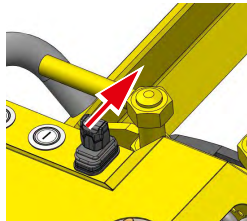
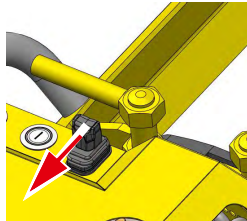
Function		Description
Forward		Moves the Shear blades together.
Back		Moves the Shear blades away from each other all the way to the rear end position.

Tab. 2-3 Position Joystick

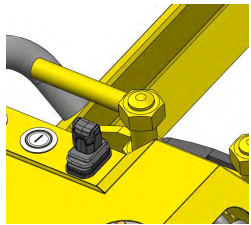
Function		Description
Center position		Prerequisite for turning on the hydraulic pump.

2.6 Colours and safety labels

2.6.1 Colouring

Table 2-4 on page 11 lists the colours for the various U-C4 +S components:

Tab. 2-4 Colouring U-C4 +S

colourname / RAL code	Components
Signal red (RAL 3001)	Emergency stop button with turn-to-release function
Signal black (RAL 9004)	Joystick
Golden yellow (RAL 1004)	Frame, housing, Guide shoe, Forks

2.6.2 Safety labels

NOTICE

If safety labels are damaged or go missing at any point in the machine's service life, the operating company must ensure that they are replaced properly. Make sure to check that the safety labels are in place and in good condition on a regular basis.

The mandatory action and warning labels shown in Figure 2-6 on page 12 can be found on the Shear blades and at the back of the U-C4 +S.

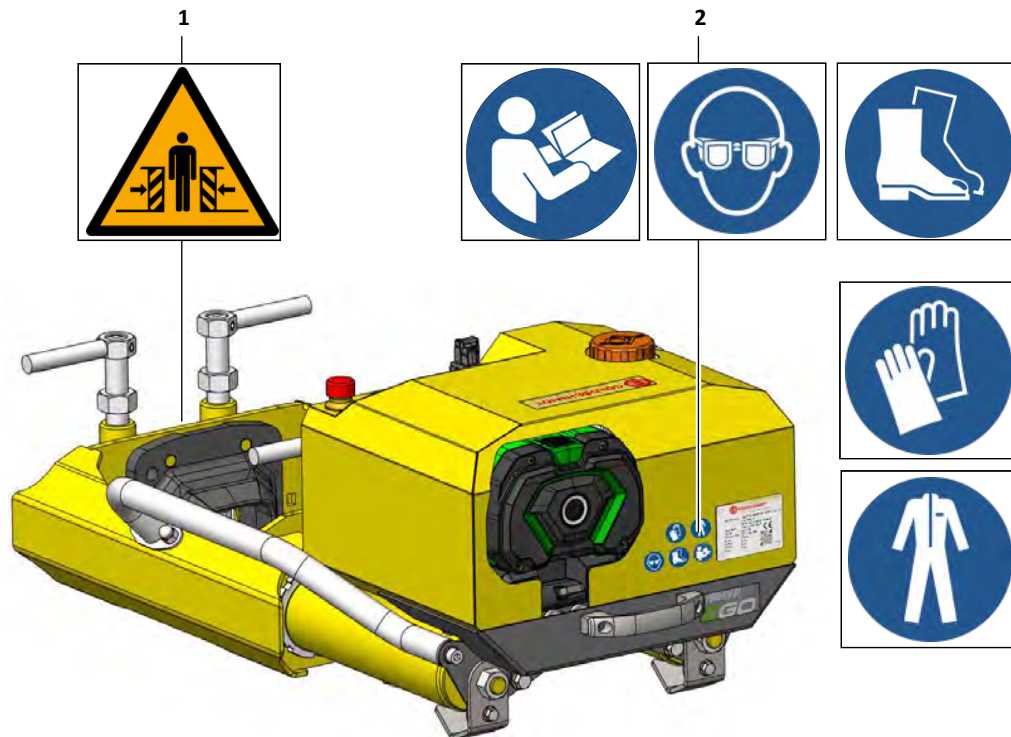

Fig. 2-6 Safety labels (front page)

- | | | | |
|---|---|---|---|
| 1 | Crush hazard warning label (Shear blades) | 2 | Mandatory action labels (please refer to Chapter "Glossary" on page ix) |
|---|---|---|---|

2.7 Safety systems

The following safety device is installed on the machine in order to prevent personal injury and environmental and property damage (please refer to Figure 2-7 on page 12).

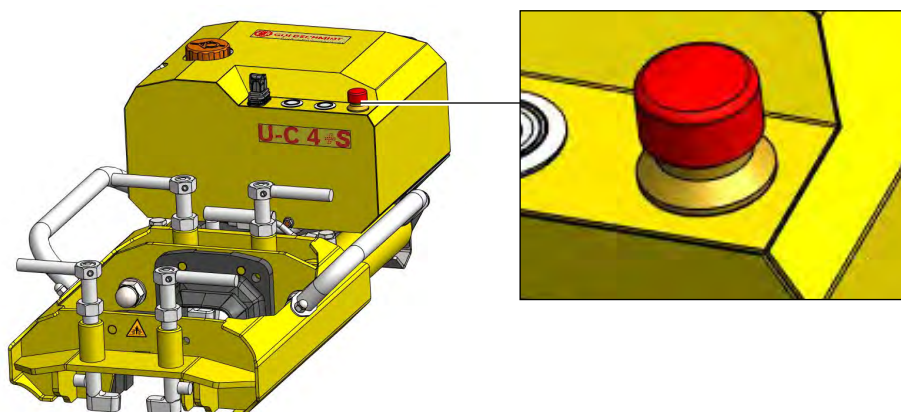

Fig. 2-7 Safety systems: Emergency-stop button

The Emergency-stop button is a twist-to-release button. Pressing the Emergency-stop button will immediately stop a shearing operation in progress.

2.8 What to do in case of emergency

If an emergency occurs, turn off the machine immediately and leave the danger zone as quickly as possible. For this purpose, there is an integrated Emergency stop button with turn-to-release function which switches off the hydraulic system when pressed.

In the event of personal injury, provide first aid immediately.

In case of fire, take the required firefighting steps immediately.

2.9 Accessory devices

NOTICE





Annex D - Accessories on Page V lists additional accessories.

2.9.1 Rechargeable battery





The batteries are EGO Power+ 56V-ARC-Lithium™ rechargeable batteries (12 Ah).

Each battery features a charge status indicator. The various battery modes are described in Table 2-5 on page 13 below:

Tab. 2-5 Battery LED indicator modes

Modes		Description
Five LEDs light up green (continuous light)		80% ≤ charge level ≤ 100%
Four LEDs light up green (continuous light)		60% ≤ charge level < 80%
Three LEDs light up green (continuous light)		40% ≤ charge level < 60%
Two LEDs light up green (continuous light)		20% ≤ charge level < 40%
One LED lights up green (continuous light)		10% ≤ charge level < 20%

Tab. 2-5 Battery LED indicator modes <continued>

Modes		Description
One LED flashes red		Charge level < 10%
Five LEDs flash red		Low voltage The battery is almost empty and needs to be charged.
Five LEDs light up red (continuous light)		The battery has overheated and needs to cool down.
No light on any of the LEDs		The hydraulic pump is switched off.

2.9.2 Charger

To charge the batteries correctly, make sure to use a "700 W RAPID+ Charger CH7000E" charger.

3 COMMISSIONING

Summary

Instructions that explain how to prepare the U-C4 +S for operation.

NOTICE

If you detect any issues, report them to your supervisor immediately. Do not put the machine back into operation until after these issues have been fixed and you receive approval for operating it again.

NOTICE

Before commissioning, always check that all operating conditions are met (see Chapter 2.3 "Operating conditions" on page 5).

NOTICE

Turn off the hydraulic pump before removing the Weld shear from the rail.

The following must be carried out before putting the machine into operation:

1. Check all included contents to make sure they are complete.

If any contents are missing, please contact the customer service team (please refer to Chapter 10 "Customer Service" on page 46).

2. Visually inspect the U-C4 +S and the battery for damage.

Damaged components and machine parts will need to be replaced. Please contact the customer service team (please refer to Chapter 10 "Customer Service" on page 46).

If you notice any leaks, stop all work immediately and follow the instructions in Chapter 6 "Fault, cause and elimination" on page 30.

3. Check the oil level.

NOTICE

Make sure that the Shear blades are in their end position.

The oil level must be 2–5 cm below the filling edge.

Refill the hydraulic oil if the oil level is too low (see Chapter 4.2 "Refilling hydraulic oil" on page 20).

Drain the necessary amount of hydraulic oil if the oil level is above the filling edge (please refer to Chapter 4.4 "Draining hydraulic oil" on page 24).

4. Make sure that the Shear blades are undamaged.

Damaged Shear blades must be replaced without fail (please refer to Chapter 4.6 "Mounting the shear blades" on page 26).

5. Carry out a test run (please refer to Chapter 3.1 "Test run" on page 16).

3.1 Test run

CAUTION

RISK OF INJURY.

The U-C4 +S Weld shear weighs a total of 45 kg / 99 lbs. Having a single person attempt to carry it by themselves may result in injury.

Make sure to always use two people to set the U-C4 +S down in place and lift it off.

CAUTION

CRUSH HAZARD.

There is a crush hazard when moving the Shear blades together.

Make absolutely sure that your limbs are outside of the shearing area.

Exercise extreme caution when carrying out a shearing operation.

NOTICE

Check the Weld shear for leaks before the shearing operation. Do not, under any circumstance, use it if there are any leaks!

Follow the steps below in order to carry out a test run:

1. Set the U-C4 +S Weld shear down on the rail.

CAUTION

CRUSH HAZARD.

There is a crush hazard when setting the machine on a rail.

Do not, under any circumstance, reach between the rail and the battery-operated weld shear.

To set down the machine, use the handles intended for that purpose.

NOTICE

Check the Guide shoes' position before setting the Weld shear down in place.

The Guide shoes must be in their transport position.

2. Push the Fork down to center the Weld shear on the track.

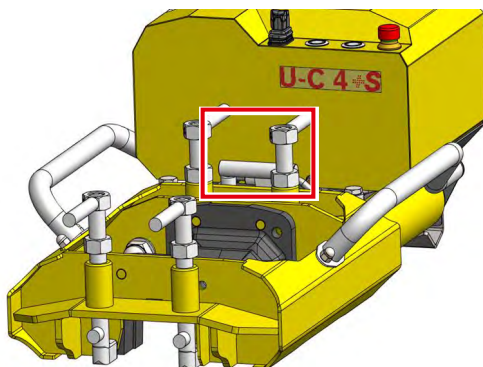

3. Use the nuts to adjust the guide shoes' height evenly until you get a clearance of approx. 1–2 mm underneath the rail head (operating position).

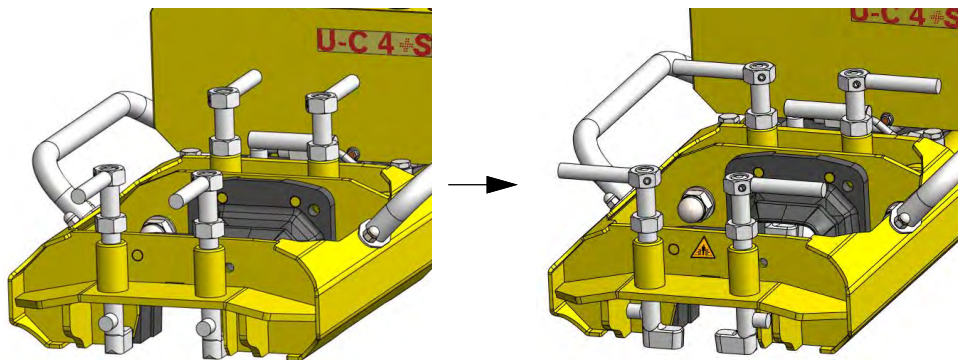

4. Press the ON button to switch on the hydraulic pump.

NOTICE

Make sure that the Joystick is in its center position so that you will be able to turn on the hydraulic pump.

After turning the hydraulic pump on, the buttons (ON button and OFF button) will light up with a solid green light.



5. Push the Joystick forward to start moving the Shear blades together.
Once the Shear blades have been moved together completely, move the Joystick to its center position and wait for approx. one (1) second. The motor's noise level will increase.

NOTICE

Continuously monitor the shearing process at all times. Immediately press the Emergency-stop button if necessary.

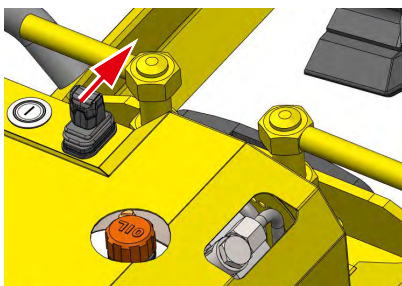

6. Pull the Joystick back and move the Shear blades completely back to their end position.

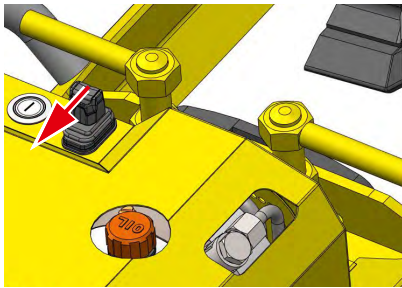

7. Press the OFF button to turn off the hydraulic pump.

After turning the hydraulic pump off, the solid light on the buttons (ON button and OFF button) will turn off.

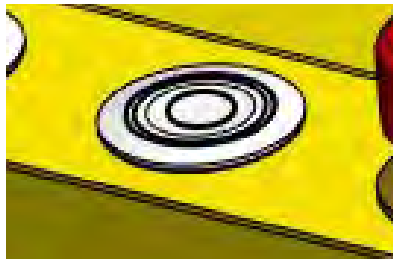

8. Move the guide shoes to the transport position.

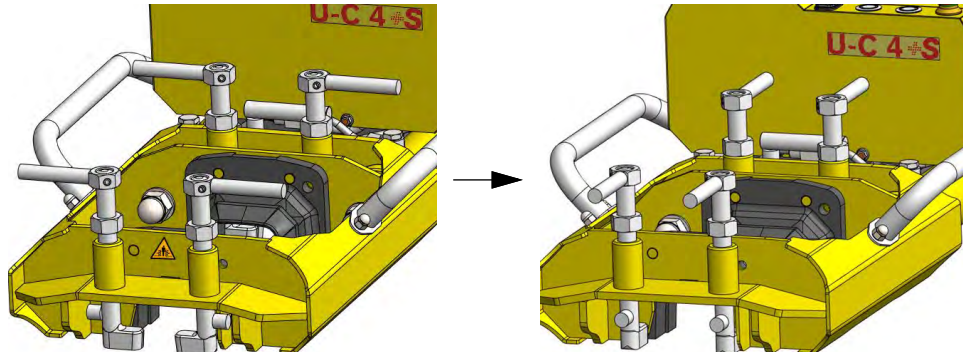

9. Push the Fork up.

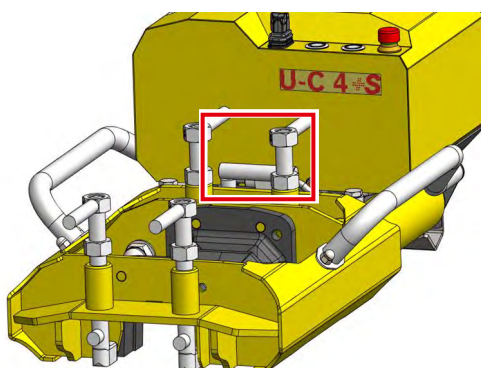

10. Lift the U-C4 +S Weld shear off from the rail and set it to the side.

4 OPERATION

Summary

Instructions used to explain the main functions of the U-C4 +S.

NOTICE

Before starting any welding work, carry out a test run with the Weld shear and check the oil level.

NOTICE

If you detect any issues, report them to your supervisor immediately. Do not put the machine back into operation until after these issues have been fixed and you receive approval for operating it again.

NOTICE

Whenever you are not operating the machine, make sure that it cannot be turned on by accident. Always use the emergency stop button to safely switch off the machine and prevent it from being switched on again, or remove the battery from the device.

NOTICE

Wear personal protection equipment.

NOTICE

Turn off the hydraulic pump before removing the Weld shear from the rail.

NOTICE

Make sure that there is no risk of electric shock.

NOTICE

Do not place the Weld shear in water or hose it down.

4.1 Inserting the batteries

NOTICE

Do not, under any circumstance, use damaged batteries.

NOTICE

Only use the EGO Power+ 56V-ARC-Lithium™ battery.

Follow the steps below to insert the batteries correctly:

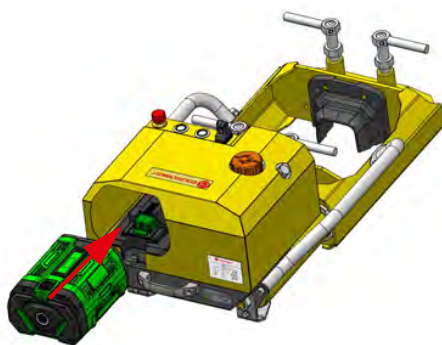

1. Fully insert the battery into the battery holder.

When the battery has been inserted properly all the way, you will hear it click into place.

4.2 Refilling hydraulic oil

NOTICE

Always make sure that everything is clean when replenishing hydraulic oil.

Dirt in the hydraulic system can cause hydraulic lines to become clogged and/or damage to the hydraulic pump.

NOTICE

If the oil volume in the tank is too low, the hydraulic pump will run dry. This can result in critical damage after just a short time.



CAUTION

RISK OF INJURY.

There is a risk of injury due to fire.

Hydraulic oil and flying sparks can result in fires.

Make sure not to replenish the oil while welding or grinding work (flying sparks) is being carried out nearby.

Follow the steps below to refill the hydraulic oil correctly:

1. Make sure that the Shear blades are fully retracted and in their end position.
Pull the Joystick back and move the Shear blades completely back to their end position.

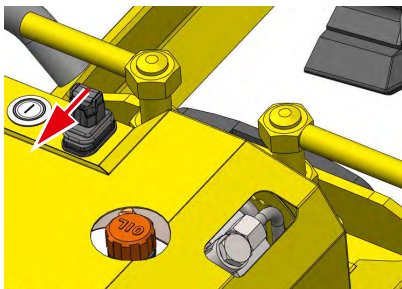

2. Press the OFF button to turn off the Weld shear.
3. Remove the battery (please refer to Chapter 4.5 "Removing the batteries" on page 25).
4. Turn the Oil filler / oil drain plug counterclockwise to open the oil tank.



5. Use a suitable funnel to pour in the hydraulic oil.

NOTICE

Only hydraulic oil of viscosity class ISO VG 22 must be used when refilling.

NOTICE

The tank has a volume of 600 ml.

NOTICE

Make sure not to overfill the hydraulic oil tank. In other words, make sure to observe the maximum fill level so that there will be enough space in the tank for hydraulic oil from the return line.

Overfilling may cause damage to the hydraulic pump.

6. Check the oil level in the meantime, and top up if necessary.
The oil level must be 2–5 cm below the filling edge.
7. Turn the Oil filler / oil drain plug clockwise to close the oil tank.



8. Insert the battery (see Chapter 4.1 "Inserting the batteries" on page 19).
9. Carry out the shearing operation if applicable (please refer to Chapter 4.3 "Carrying out a shearing operation" on page 21).

4.3 Carrying out a shearing operation

CAUTION**RISK OF INJURY.**

The U-C4 +S Weld shear weighs a total of 45 kg / 99 lbs. Having a single person attempt to carry it by themselves may result in minor injury.

Make sure to always use two people to set the U-C4 +S down in place and lift it off.

CAUTION**CRUSH HAZARD.**

There is a crush hazard when moving the Shear blades together.

Make absolutely sure that your limbs are outside of the shearing area.

Exercise extreme caution when carrying out a shearing operation.

NOTICE

Check the Weld shear for leaks before the shearing operation. Do not, under any circumstance, use it if there are any leaks!

NOTICE

Make sure that all preparation work has been carried out in conformity with the instructions for shearing!

Follow the steps below in order to carry out a test run:

1. Set the U-C4 +S Weld shear down on the rail.

**CAUTION****CRUSH HAZARD.**

There is a crush hazard when setting the machine on a rail.
Do not, under any circumstance, reach between the rail and the weld shear.
To set down the machine, use the handles intended for that purpose.

NOTICE

Check the Guide shoes' position before setting the Weld shear down in place.
The Guide shoes must be in their transport position.

2. Push the Fork down to center the Weld shear on the track.

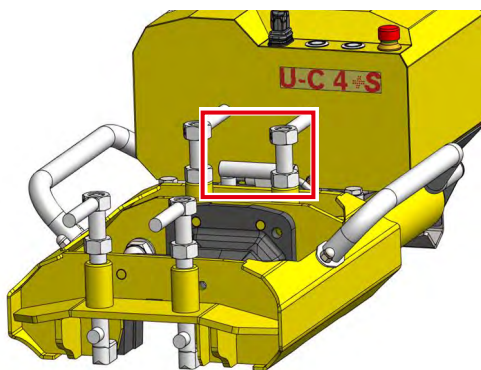

3. Use the nuts to adjust the guide shoes' height evenly until you get a clearance of approx. 1–2 mm underneath the rail head (operating position).

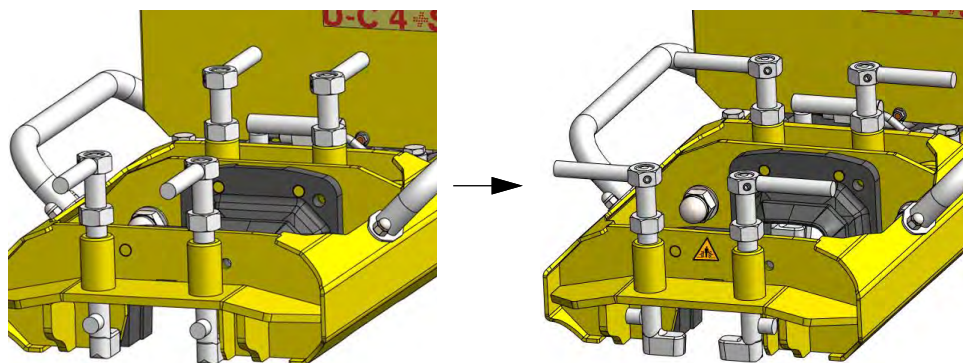

4. Press the ON button to switch on the hydraulic pump.

NOTICE

Make sure that the Joystick is in its center position so that you will be able to turn on the hydraulic pump.

After turning the hydraulic pump on, the buttons (ON button and OFF button) will light up with a solid green light.

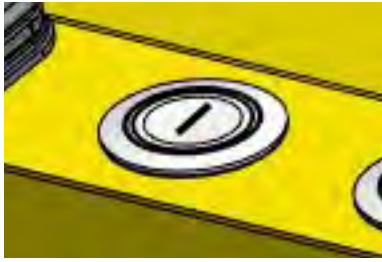

5. Push the Joystick forward to start moving the Shear blades together.

Once the Shear blades have been moved together completely, move the Joystick to its center position and wait for approx. one (1) second. The motor's noise level will increase.

NOTICE

Continuously monitor the shearing process at all times. Immediately press the Emergency-stop button if necessary.

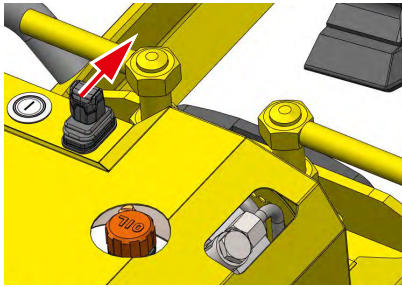

6. Pull the Joystick back and move the Shear blades completely back to their end position.

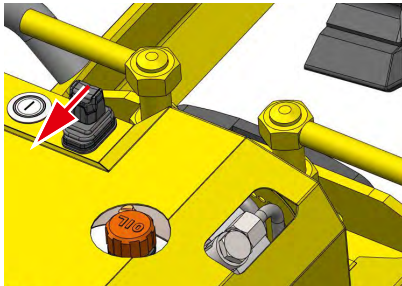

7. Press the OFF button to turn off the hydraulic pump.

After turning the hydraulic pump off, the solid light on the buttons (ON button and OFF button) will turn off.

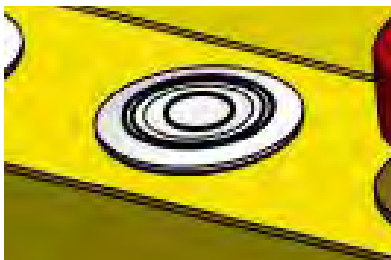

8. Move the guide shoes to the transport position.

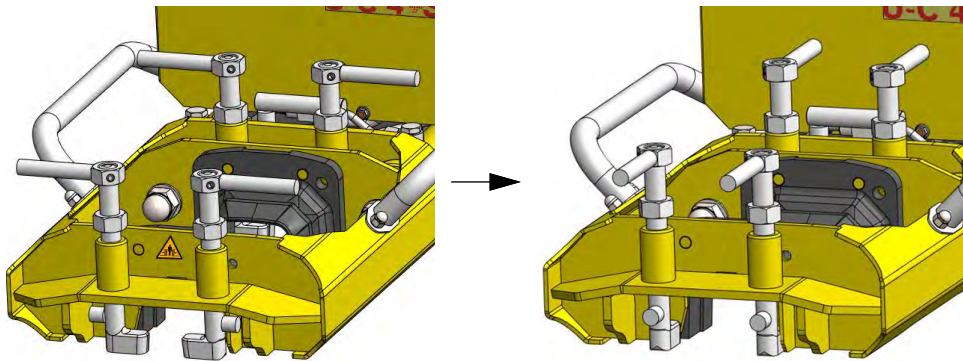

9. Push the Fork up.

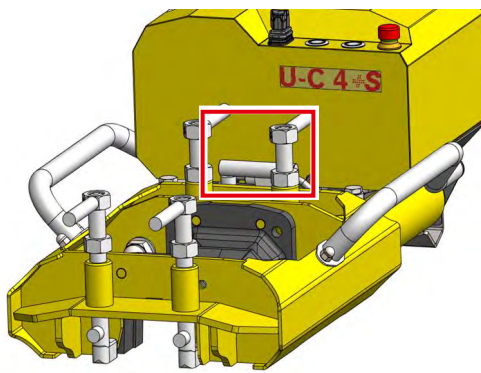

10. Lift the U-C4 +S Weld shear off from the rail and set it to the side.
11. If necessary, knock off the sheared-off excess weld metal with a hammer.

4.4 Draining hydraulic oil

NOTICE

Make sure everything is clean.
Dirt in the hydraulic system can cause hydraulic lines to become clogged and/or damage to the hydraulic pump.

Follow the steps below to drain the hydraulic oil correctly:

1. Make sure that the Shear blades are fully retracted and in their end position.
Pull the Joystick back and move the Shear blades completely back to their end position.

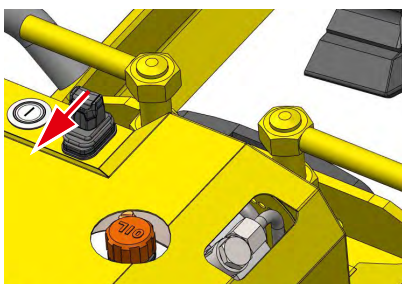

2. Press the OFF button to turn off the Weld shear.

3. Remove the battery (please refer to Chapter 4.5 "Removing the batteries" on page 25).
4. Turn the Oil filler / oil drain plug counterclockwise to open the oil tank.



5. Use a syringe extractor to draw hydraulic oil from the tank.

NOTICE

If the oil volume in the tank is too low, the hydraulic pump will run dry. This can lead to critical damage after just a short time.



Used oil must be disposed of in accordance with national and international laws and regulations.
For more detailed information, please refer to Chapter 9 "Disposal" on page 44.

6. Check the oil level in the meantime, and top up if necessary.
The oil level must be 2–5 cm below the filling edge.
7. Turn the Oil filler / oil drain plug clockwise to close the oil tank.



8. Insert the battery (see Chapter 4.1 "Inserting the batteries" on page 19).
9. Carry out the shearing operation if applicable (please refer to Chapter 4.3 "Carrying out a shearing operation" on page 21).

4.5 Removing the batteries

NOTICE

Make sure that the battery has been removed before storage.

Follow the steps below to remove the batteries correctly:

1. Press the Latch hook downwards and release the spring.

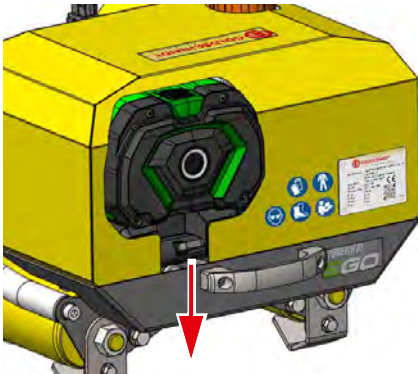

2. Remove the battery from the battery holder.

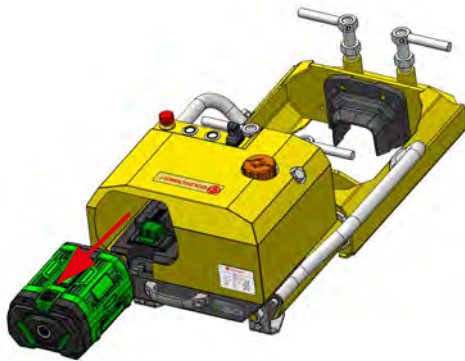

4.6 Mounting the shear blades

NOTICE

Make absolutely sure to only use Shear blades that match the rail profile in question.

Follow the steps below to install the Shear blades:

1. Position the Shear blades over the mounting pins.
2. Screw the Shear blades in place with a suitable wrench.

NOTICE

Use two M12 x 25 mm hex cap screws for each Shear blade.

4.7 Removing the shear blades

Follow the steps below to remove the Shear blades:

1. Use a suitable wrench to undo the threaded joints.

NOTICE

Store the four M12 x 25 mm hex cap screws in a safe place.

2. Remove the Shear blades.

5 DECOMMISSIONING

Summary

Instructions used to explain how to shut down the U-C4 +S as preparation for maintenance, transportation, or storage.



RISK OF INJURY.

The U-C4 +S Weld shear weighs a total of 45 kg / 99 lbs. Having a single person attempt to carry it by themselves may result in injury. Make sure to always use two people to set the U-C4 +S down in place and lift it off.

1. Pull the Joystick back and move the Shear blades completely back to their end position.

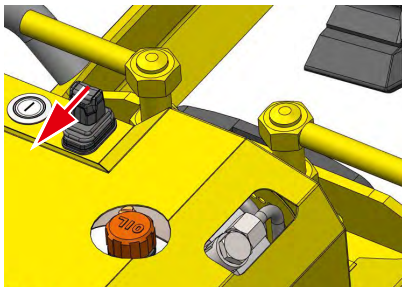

2. Press the OFF button to turn off the hydraulic pump.

After turning the hydraulic pump off, the solid light on the buttons (ON button and OFF button) will turn off.

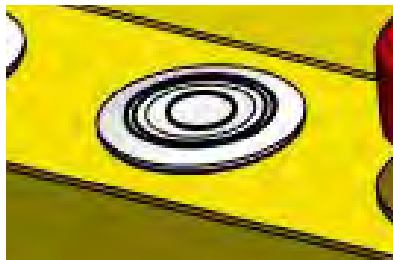

3. Move the guide shoes to the transport position.

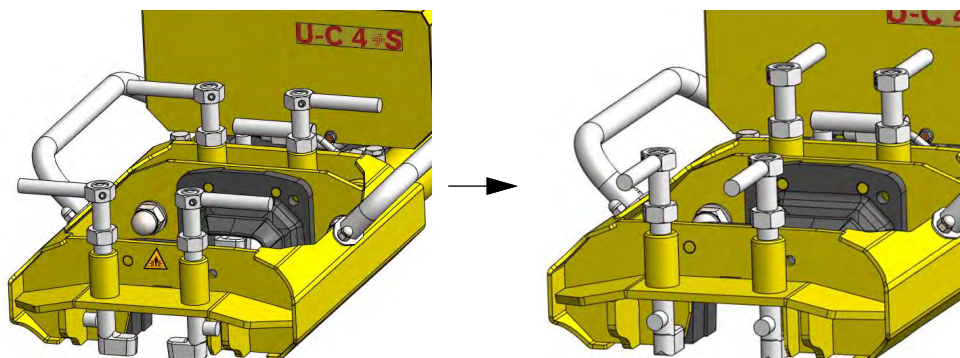

4. Push the Fork up.

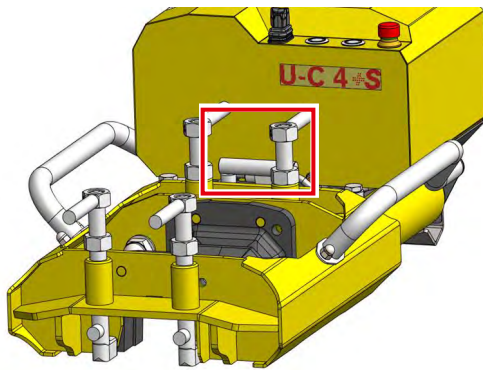

5. Lift the U-C4 +S Weld shear off from the rail and set it to the side.
6. Remove the battery (EGO Power+ 56V-ARC-Lithium™) from the battery-operated weld shear (please refer to Chapter 4.5 "Removing the batteries" on page 25).

6 FAULT, CAUSE AND ELIMINATION

Summary

Identifying problems and fixing them.

NOTICE

All maintenance, servicing, and inspection work must be carried out exclusively by trained specialized personnel.

NOTICE



Wear the required personal protection equipment.

NOTICE

If necessary, contact the customer service team (please refer to Chapter 10 "Customer Service" on page 46) in order to get information for maintenance steps or repairs.

The following Table 6-1 on page 30 lists potential problems, their cause, and how to fix them.

FCE 6-1 Fault, cause and elimination

Defect	Cause	Elimination
1 battery LED flashes red 	Battery charge level < 10%	1. Charge the battery with a compatible charger.
Five battery LEDs flash red 	The battery is almost empty and needs to be charged immediately.	
Five battery LEDs light up red (continuous light) 	Battery overheating	1. Let the battery cool down.

FCE 6-1 Fault, cause and elimination <continued>

Defect	Cause	Elimination
The hydraulic pump does not turn on when the ON button is pressed.	The battery has not been properly inserted all the way into the battery holder.	<ol style="list-style-type: none"> 1. Check to make sure that the battery has been inserted properly and insert it properly otherwise. The battery must be inserted all the way into the battery holder.
	The electrical contacts of the battery or battery holder are dirty	<ol style="list-style-type: none"> 1. Clean the contacts.
	The Emergency-stop button has been pressed and has not been released (LED flashing green)	<ol style="list-style-type: none"> 1. Reset the Emergency-stop button by turning it to release it.
	There is an electrical problem	<ol style="list-style-type: none"> 1. Please contact the customer service team (please refer to Chapter 10 "Customer Service" on page 46).
	The Joystick is not in its center position.	<ol style="list-style-type: none"> 1. Move the Joystick to its center position. 2. Press the ON button again.

7 MAINTENANCE AND CARE

Summary

Overview of maintenance and repair tasks and the materials required for them, as well as instructions on how to carry them out.



WARNING

RISK OF INJURY.

Incorrect, untimely, or poorly considered maintenance work may result in personal injury or to damage to the machine.

- Remove the battery before carrying out any maintenance work.
- Do not carry out any maintenance work without first depressurizing the hydraulic system completely.
- Observe all maintenance instructions and intervals.
- Components must be replaced exclusively with identical spare parts. All component manufacturer specifications must be observed without fail during installation.



CAUTION

RISK OF INJURY.

Putting the machine back into operation intentionally and/or accidentally may result in injury.

Remove the battery to make sure that the U-C4 +S Weld shear cannot be put back into operation intentionally or accidentally during maintenance and repair work.



Environmentally hazardous substances must be properly disposed of in compliance with all applicable requirements and regulations.

Make sure to observe the manufacturer's data sheets and safety data sheets.

For more detailed information, please refer to Chapter 9 "Disposal" on page 44.

NOTICE

All maintenance, servicing, and inspection work must be carried out exclusively by trained specialized personnel.

NOTICE

Wear the required personal protection equipment.

7.1 Maintenance schedule

The maintenance schedule shows the interval at which maintenance tasks must be carried out while taking into account specific maintenance steps (please refer to Table 7-1 on page 33).

Tab. 7-1 Maintenance schedule

Maintenance task	interval					
	Every time before putting the machine into operation	Every 20 operating hours	Every 40 operating hours	Every 100 operating hours	Annually	As necessary
Visual inspection of the U-C4 +S	X					X
Visual inspection and condition check Safety labels and rating plate			X			X
Cleaning the U-C4 +S		X				X
Oil level check	X					X
Checking for leaks	X					X
Visual inspection and condition check Safety labels and rating plate	X					X
Changing the hydraulic oil					X	X
Removing burrs and offsets						X
Regrinding the Shear blades						X

7.2 Visual inspection of the U-C4 +S

Ambient conditions

No special ambient conditions need to be observed.

Personnel
Specialized personnel

Tools and materials
-

Maintenance 7-1 Visual inspection

Maintenance steps	Tools / materials
<p>1. Visual inspection of general condition</p> <p>1- 001 Carry out a visual inspection checking for damage, cracks, broken parts, and dents.</p> <p>Damaged components must not be put into operation and must be replaced.</p> <p>Please contact the customer service team (please refer to Chapter 10 "Customer Service" on page 46).</p>	

7.3 Cleaning the U-C4 +S

NOTICE Do not place the Weld shear in water or hose it down.

Ambient conditions
No special ambient conditions need to be observed.

Personnel
Specialized personnel

Tools and materials
Cleansing tissue

Maintenance 7-2 Cleaning

Maintenance steps	Tools / materials
<p>1. Cleaning the U-C4 +S</p>	

Maintenance 7-2 Cleaning <continued>

Maintenance steps	Tools / materials
1- 001 Remove excess soiling from the Shear blades' contact surfaces with an appropriate cleaning cloth.	Cleansing tissue
1- 002 Remove excess soiling from the guide frame's inner surfaces with an appropriate cleaning cloth.	

7.4 Oil level check

Ambient conditions
No special ambient conditions need to be observed.

Personnel
Specialized personnel

Tools and materials
Hydraulic oil with ISO VG 22 viscosity grade (if it is necessary to replenish the hydraulic oil)
Funnel (if it is necessary to replenish the hydraulic oil)

Maintenance 7-3 Oil level check

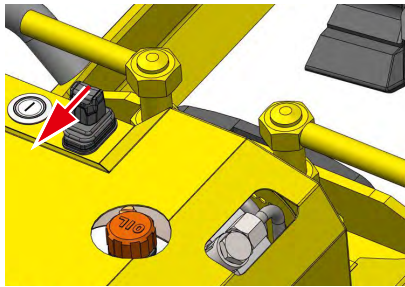
Maintenance steps	Tools / materials
<p>1. Moving the Shear blades to their end position</p> <p>1- 001 Make sure that the Shear blades are fully retracted and in their end position.</p> <p>Pull the Joystick back and move the Shear blades completely back to their end position.</p> 	
<p>2. Turning off the hydraulic system</p> <p>2- 001 Press the OFF button to turn off the Weld shear.</p>	

Maintenance 7-3 Oil level check <continued>

Maintenance steps	Tools / materials
<p>3. Oil level check</p> <p>3- 001 Turn the Oil filler / oil drain plug counterclockwise to open the oil tank.</p> <p>3- 002 Check the oil level. The oil level must be 2–5 cm below the filling edge.</p> 	
<p>4. Replenishing or draining hydraulic oil (as necessary)</p> <p>4- 001 Replenish the hydraulic oil if the oil level is below the specified limit (please refer to Chapter 4.2 "Refilling hydraulic oil" on page 20).</p> <p>4- 002 Drain hydraulic oil if the oil level is above the specified limit (please refer to Chapter 4.4 "Draining hydraulic oil" on page 24).</p>	<p>Hydraulic oil with ISO VG 22 viscosity grade</p> <p>Funnel</p>

7.5 Checking for leaks

Ambient conditions
No special ambient conditions need to be observed.
Personnel
Specialized personnel
Tools and materials
-

Maintenance 7-4 Checking for leaks

Maintenance steps	Tools / materials
1. Visual inspection	

Maintenance 7-4 Checking for leaks <continued>

Maintenance steps	Tools / materials
<p>1- 001 Check the Weld shear for damage.</p> <p>Damaged components must not be put into operation and must be replaced.</p> <p>Please contact the customer service team (please refer to Chapter 10 "Customer Service" on page 46).</p>	
<p>1- 002 Check the Weld shear for leaks.</p> <p>If there are any leaks, take the Weld shear out of service.</p> <p>Then contact the customer service team (please refer to Chapter 10 "Customer Service" on page 46).</p>	

7.6 Visual inspection and condition check Safety labels and rating plate

Ambient conditions
No special ambient conditions need to be observed.

Personnel
Specialized personnel

Tools and materials
Rating plate Safety labels

Maintenance 7-5 Visual inspection and condition check of safety labels and rating plate

Maintenance steps	Tools / materials
<p>1. Visual inspection and condition check</p> <p>1- 001 Check that all safety labels are present and legible.</p> <p>Missing and illegible safety labels must be replaced.</p>	Safety labels
<p>1- 002 Check that the rating plate is present and legible.</p> <p>If the rating plate is missing or illegible, it must be replaced.</p>	Rating plate

7.7 Changing the hydraulic oil

Ambient conditions

No special ambient conditions need to be observed.

Personnel

Specialized personnel

Tools and materials

Hydraulic oil with ISO VG 22 viscosity grade

Funnel

Syringe extractor

Drain container (minimum capacity of 600 ml)

Maintenance 7-6 Changing the hydraulic oil

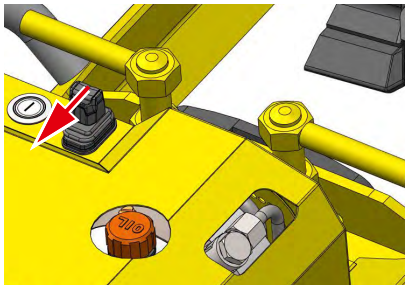
Maintenance steps	Tools / materials
<p>1. Moving the Shear blades to their end position</p> <p>1- 001 Make sure that the Shear blades are fully retracted and in their end position.</p> <p>Pull the Joystick back and move the Shear blades completely back to their end position.</p> 	
<p>2. Turning off the hydraulic system</p> <p>2- 001 Press the OFF button to turn off the Weld shear.</p>	
<p>3. Draining used oil</p> <p>3- 001 Drain the used oil (please refer to Chapter 4.4 "Draining hydraulic oil" on page 24).</p>	<p>Drain container (minimum capacity of 600 ml)</p> <p>Syringe extractor</p>
<p>4. Replenishing hydraulic oil</p> <p>4- 001 Replenish the hydraulic oil (please refer to Chapter 4.2 "Refilling hydraulic oil" on page 20).</p>	<p>Hydraulic oil with ISO VG 22 viscosity grade</p> <p>Funnel</p>

7.8 Removing burrs and offsets

Ambient conditions

No special ambient conditions need to be observed.

Personnel

Specialized personnel

Tools and materials

Angle grinder

Maintenance 7-7 Removing burrs and offsets

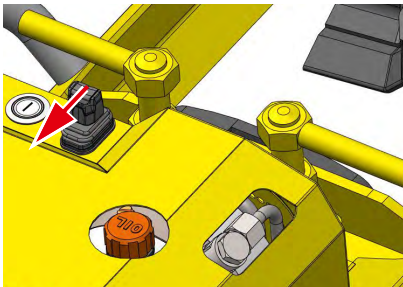
Maintenance steps	Tools / materials
<p>1. Moving the Shear blades to their end position</p> <p>1- 001 Make sure that the Shear blades are fully retracted and in their end position.</p> <p>Pull the Joystick back and move the Shear blades completely back to their end position.</p> 	
<p>2. Turning off the hydraulic system</p> <p>2- 001 Press the OFF button to turn off the Weld shear.</p>	
<p>3. Removing burrs</p> <p>3- 001 Use an angle grinder to carefully remove the burrs on the inside of the Shear blades.</p>	Angle grinder
<p>4. Removing offsets</p>	Angle grinder

Maintenance 7-7 Removing burrs and offsets <continued>

Maintenance steps	Tools / materials
4- 001 Press the ON button to turn on the Weld shear. After turning the hydraulic pump on, the buttons (ON button and OFF button) will light up with a solid green light.	
4- 002 Push the Joystick forward to start moving the Shear blades together.	
4- 003 Press the OFF button to turn off the Weld shear.	
4- 004 Use an angle grinder to carefully grind the offsets on the inside of the blades.	
4- 005 Press the ON button to turn on the Weld shear. After turning the hydraulic pump on, the buttons (ON button and OFF button) will light up with a solid green light.	
4- 006 Pull the Joystick back and move the Shear blades back to the rear end position.	

7.9 Regrinding the Shear blades

Ambient conditions
No special ambient conditions need to be observed.

Personnel
Specialized personnel

Tools and materials
Angle grinder

Maintenance 7-8 Regrinding the Shear blades

Maintenance steps	Tools / materials
1. Removing the Shear blades 1- 001 Remove the Shear blades from the U-C4 +S. Please refer to Chapter 4.7 "Removing the shear blades" on page 26.	
2. Regrinding the Shear blades	Angle grinder

Maintenance 7-8 Regrinding the Shear blades <continued>

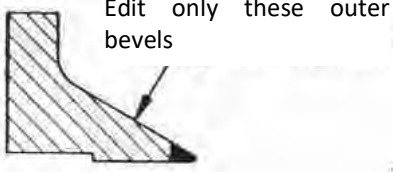
Maintenance steps	Tools / materials
<p>2- 001 If the outer area of the cutting edges is heavily worn, regrind them.</p>  <p>NOTICE If it is not possible to regrind the Shear blades, you will need to replace them.</p> <p>NOTICE When bringing the Shear blades together, check whether the cutting edges come together along the entire length of the cutting edges. Regrind them if necessary.</p>	
<p>3. Installing the Shear blades</p> <p>3- 001 Install the Shear blades.</p> <p>Please refer to Chapter 4.6 "Mounting the shear blades" on page 26.</p>	

8 TRANSPORT AND STORAGE

Summary

Provides information and uses instructions to explain the steps required for transportation, storage, and putting the machine back into operation.



CAUTION

RISK OF INJURY.

The U-C4 +S Weld shear weighs a total of 45 kg / 99 lbs. Having a single person attempt to carry it by themselves may result in injury. Make sure to always use two people to set the U-C4 +S down in place and lift it off.

8.1 Transporting the U-C4 +S

NOTICE

When transporting the machine, make sure to comply with all safety and accident prevention regulations.

Follow the steps below to transport the U-C4 +S Weld shear correctly:

1. Switch off the machine.
For more detailed information, please refer to Chapter 5 "Decommissioning" on page 28.
2. Transport the Weld shear to its intended destination with suitable equipment.

NOTICE

Use suitable devices to secure the machine during transportation!

8.2 Storing the U-C4 +S

The following storage conditions need to be adhered to in order to properly store the machine (please refer to Table 8-1):

Storage 8-1 Storage conditions

Conditions	
Ambient conditions	- Protected from exposure to UV, - Not placed directly next to heaters or other heat sources - Dust-free
Storage temperature	5 °C to 30 °C (32 °F to 104 °F)
Max. storage period	Two years (continuous)
Relative humidity	40% to 60%

Follow the steps below to store the U-C4 +S correctly:

1. Switch off the machine.
For more detailed information, please refer to Chapter 5 "Decommissioning" on page 28.
2. Transport the Weld shear to its intended storage location with suitable equipment.
For more detailed information, please refer to Chapter 8.1 "Transporting the U-C4 +S" on page 42.
3. Remove the battery.
For more detailed information, please refer to Chapter 4.5 "Removing the batteries" on page 25
4. Clean the contact surfaces for the shear blades and the insides of the guide frame.
5. Properly store the U-C4 +S at the corresponding storage location.

NOTICE

Store the Weld shear on pallets or shelves (not directly on the floor or against walls) in order to prevent the ingress of moisture.

NOTICE

Store the Weld shear upright.

NOTICE

If necessary, use a protective cover/dust cover to protect internal parts from soiling and other impurities.

8.3 Putting the U-C4 +S back into operation

Follow the steps below in order to put the machine back into operation:

1. Remove the U-C4 +S from its storage location.
2. If you used a protective cover or dust cover, remove it.
3. Transport the U-C4 +S to the place where it will be used.
For more detailed information, please refer to Chapter 8.1 "Transporting the U-C4 +S" on page 42.
4. Insert the battery.
For more detailed information, please refer to Chapter 4.1 "Inserting the batteries" on page 19.
5. Go through all the preparation steps.
For more detailed information, please refer to Chapter 3 "Commissioning" on page 15.

9 DISPOSAL

Summary

How to properly dispose of the U-C4 +S and its components and/or accessories.



Used oil must be disposed of in accordance with national and international laws and regulations.



The disposal of rechargeable batteries/accumulators is regulated by EU Battery Directive (EU 2023/1542). The machine must be disposed of exclusively by trained specialized personnel or by specialized companies that have been tasked with this disposal. Always ensure that disposal takes place in an environmentally responsible manner!

NOTICE

At the end of its service life, the U-C4 +S must be separated from unsorted municipal waste and properly disposed of in compliance with all applicable national and international legislation and regulations.

NOTICE

Hydraulic oils, as well as rags and similar items contaminated with hydraulic oil, must be collected in appropriately labelled containers and disposed of properly.

Next Steps

1. Switch off the machine (please refer to Chapter 5 "Decommissioning" on page 28).
2. Remove the battery (EGO Power+ 56V-ARC-Lithium™) from the U-C4 +S (please refer to Chapter 4.5 "Removing the batteries" on page 25).

NOTICE

Follow EGO's disposal instructions (please refer to Chapter 1.4 "Further applicable documents" on page 4).

3. Empty the oil tank completely (see Chapter 4.4 "Draining hydraulic oil" on page 24).

NOTICE

Dispose of the old oil in accordance with the national and international laws and regulations, and follow the manufacturer's disposal instructions.

4. Dispose of the Weld shear at an authorized recycling facility.

9.1 Waste code numbers (WCN) in the EU

The information in this chapter is intended to ensure that the U-C4 +S will be disposed of in an environmentally friendly manner. For this purpose, the structure was analyzed and the waste generated during disposal was, as far as possible, assigned to the waste types identified in the European Waste List with a six-digit waste code number.

The waste code numbers marked (*) are hazardous within the meaning of Section 41 of the Circular Economy Act. This also applies to waste collected by public waste disposal authorities pursuant to Section 15 of the Circular Economy Act.

The waste designations corresponding to the waste code numbers are listed in Table 9-1.

Tab. 9-1 Waste code numbers (WCN)

Waste code numbers (WCN)	Waste designation
13 01	Hydraulic oil waste
02 01 10	Scrap metal
08 01 11*	Paint and varnish waste containing organic solvents or other hazardous substances.
08 01 21*	Paint or varnish remover waste
15 02 02*	Absorbent and filter materials (including oil filters not otherwise specified), wiping cloths and protective clothing contaminated by dangerous substances
16 02	Waste from electrical and electronic devices
16 06	Batteries and accumulators
17 02 03	Plastic
17 04 01	Copper, bronze, brass
17 04 02	Aluminum
17 04 05	Iron and steel
17 04 11	Cables except those falling under 17 04 10* (cables containing oil, coal tar or other dangerous substances).
20 01 26	Oils and fats other than those falling under 20 01 25*.

10 CUSTOMER SERVICE

Summary

Contact information for the manufacturer in the event that you need to get in touch in order to buy spare parts, return an old machine, or get a problem fixed.

10.1 Contact details

You can find the contact information in Table 10-1 below:

Tab. 10-1 Contact details

Address	ELEKTRO-THERMIT GMBH & CO.KG A GOLDSCHMIDT COMPANY Chemiestraße 24 06132 Halle (Saale)
Phone	+49 345 7795-600
Fax	+49 345 7795-770
e-mail	et@goldschmidt.com
Internet	www.goldschmidt.com

ANNEX A - TECHNICAL DATA

NOTICE

For more technical data about supplier components, refer to Chapter 1.4 "Further applicable documents" on page 4.

Tab. A-1 General data

General data	
Manufacturer	ELEKTRO-THERMIT GMBH & CO.KG A GOLDSCHMIDT COMPANY Chemiestraße 24 06132 Halle (Saale)
Device information	
Designation	Weld shear (U-C4 +S)
Serial number	from U-C4+S-0010

Tab. A-2 Technical data

Technical data	
Measures and weights	
Length	847 mm / 33.3 in
Height	322 mm / 12.6 in
Width	455 mm / 17.9 in
Distance between Shear blades	150 mm / 5.9 in
Weight (without battery/without shear blades)	45 kg / 99 lb
Force	200 kN / 45000 lbf
gap width	up to 75 mm / 90 mm - 2.95 in / 3.55 in
Rail type	Flat-bottom
Hydraulics	
Peak pressure	500 bar
Conveyor power	1.5 l/min
Tank volume	600 ml / 0.158 US gal
Hydraulic fluid	Hydraulic oil as per ISO VG 22 Viscosity: 15–25 cSt (40 °C / 104 °F)
Drive	
Type of battery	EGO Power+ 56V-ARC-Lithium™

Tab. A-2 Technical data <continued>

Technical data	
Battery potential	56 V
Battery capacity	7.5 Ah / 10 Ah / 12 Ah
Motor rating	1.5 kW
Motor speed	2900 rpm
Temperature ranges /Operating conditions	
Ambient temperature when operating the machine	-10 °C to +40 °C (14 °F to 104 °F)
Ambient temperature when charging the batteries	+5 °C to +40 °C (41 °F to 104 °F)
Ambient temperature while in storage	5 °C to 30 °C (41 °F to 104 °F)
Minimum oil temperature	+10 °C / 50 °F

Tab. A-3 Emissions

Emissions	
When the unit is in proper condition, the A-weighted emission sound level at the work area will be higher than 70 dB(A) during shearing. It is mandatory to wear ear defenders approved for use in the rail sector.	
Sound pressure level	75 dB(A)
Sound pressure level (shearing)	84 dB(A)

ANNEX C - DECLARATION OF CONFORMITY

TRANSLATION OF THE ORIGINAL DECLARATION

EC Declaration of Conformity

within the meaning of the EC Machinery Directive 2006/42/EC, Annex II, No. 1 A.

The manufacturer:

ELEKTRO-THERMIT GMBH & CO. KG
Chemical street 24
06132 Halle (Saale)

hereby declares that the following product

Model: Weld Shear U-C
Product name: U-C 4 +S
Serial number: U-C4+S-XXXX (XXXX starting at 0010)
Year of construction: from 2026

complies with all relevant provisions of the Machinery Directive 2006/42/EC Annex I.

Applied harmonised standards

Directive 2014/30/EU on electromagnetic compatibility (EMC)
EN ISO 12100:2011-03 Safety of machinery - General principles for design - Risk assessment and risk reduction
DIN EN 60204-1:2019-06 Safety of machinery - Electrical equipment of machines - Part 1 General requirements
EN ISO 4413:2010 Fluid power - General rules and safety requirements for hydraulic systems and their components
DIN EN 55014-1 Electromagnetic compatibility - Requirements for household appliances, electric tools and similar electrical appliances - Part 1: Emission
DIN EN 55014-2 Electromagnetic compatibility - Requirements for household appliances, electric tools and similar electrical appliances - Part 2: Immunity

Mr. Sven Kummer, Am Schenberg 20, 04349 Leipzig is authorised to submit the technical documents.

Halle (Saale), 17.03.2026



Dr.-Ing. Jörg Semmler
Managing Director

ANNEX D - ACCESSORIES

When ordering accessories, you will need to provide your U-C4 +S's model and serial number. You can find this information on the rating plate (please refer to Chapter 2.4.3 "Rating plate" on page 9).

Tab. D-1 Accessories

Accessory	Quantity
EGO Power+ 56V-ARC-Lithium™ (12 Ah)	1
Hydraulic oil	1.5 l
PE funnel	1

LIST OF FIGURES

Fig. 2-1	Main sub-assemblies U-C4 +S	7
Fig. 2-2	Shear bladetype A - flat-bottom rails.....	8
Fig. 2-3	Guide shoe positions.....	9
Fig. 2-4	Rating plate	9
Fig. 2-5	Joystick.....	10
Fig. 2-6	Safety labels (front page)	12
Fig. 2-7	Safety systems: Emergency-stop button	13
Fig. A-1	General drawings	III

LIST OF TABLES

Tab. 1-1	Qualification level	2
Tab. 1-2	Personal protection equipment	3
Tab. 1-3	Additional applicable documents – supplier documentation	4
Tab. 1-4	Additional applicable documents – manufacturer documentation	4
Tab. 2-1	Operating conditions U-C4 +S	5
Tab. 2-2	Modes ON button/OFF button	7
Tab. 2-3	Position Joystick	10
Tab. 2-4	Colouring U-C4 +S	11
Tab. 2-5	Battery LED indicator modes	13
Tab. 7-1	Maintenance schedule	33
Tab. 9-1	Waste code numbers (WCN)	45
Tab. 10-1	Contact details	46
Tab. A-1	General data	I
Tab. A-2	Technical data	I
Tab. A-3	Emissions	II
Tab. D-1	Accessories	V

INDEX**A**

Abbreviations	viii
Accessories	
Rechargeable battery	13
Accessory	V
Accessory devices	13
Additional applicable documents – manufacturer documentation	4
Additional applicable documents – supplier documentation	4
Ambient temperature	5, II
ASN	45

B

Battery	
Battery bracket	19
Charger	14
Flat	30
Inserting	19
insertion	31
Overheated	14, 30
Removal	25
Battery charge level	30

C

Charge status	13
Charger	14
Type	14
Checking for leaks	33
Circular Economy Act	45
Coloring	11
Colouring	11
golden yellow	11
signal black	11
signal red	11
Commissioning	15
Construction description	5
Contact details	46
Conveyor power	I
Crush hazard warning label	12
Customer Service	
e-mail	46
Fax	46
Website	46
Customer service	46
contact details	46
Telephone	46

D

Declaration of conformity	IV
---------------------------	----

Decommissioning	28
Defects	30
Device information	I
Dimensions	I
Disposal	44
batteries and accumulators	45
cables	45
scrap metal	45
used oil	45
waste code numbers	45

E

Emergency	13
Emergency-stop button	13

F

Fault, cause and elimination	30
Faults	30
Function description	5
Further applicable documents	4

G

General drawings	III
Glossary	ix
Guide shoe	8
operating position	9
transport position	9

H

History of Changes	iii
Humidity	42
Hydraulic oil	
draining	24
replenishing	20
Hydraulic oil ISO VG 22	I
Hydraulic pump	
inoperative	31

I

Intended use	5
Internet	46
Introduction	1
Information about this document	1
Requirements for operators	1
Validity	1

J

Joystick	10
back	10
center position	11
forward	10

L		Charge status modes	13
<hr/>		Low voltage	14
List of accessories	V	Type	I
List of figures	VI	Rechargeable battery LED	13
List of tables	VII	Recommissioning	43
M		Requirement	1
<hr/>		S	
Main sub-assemblies	6	Safety instructions	
Maintenance		Explanations	iv
Cleaning	33	general	v, vii
Maintenance schedule	33	Safety labels	11
Rating plate inspection	33	Safety systems	12
Regrinding shear blades	33	Serial number	I
Removing burrs/offsets	33	Shear blades	
Safety label inspection	33	Fixing (burrs/offsets)	33
Maintenance and care	32	general	8
Maintenance schedule	33	Regrinding	33
Maintenance task	33	removing	26
Mandatory action label		shear blades type A	8
read the operation manual	12	Shearing operation	21
Mandatory and warning signs	11	Sound pressure level	II
Manufacturer	I	Spare parts	V
Modes		Storage	42
Charge status	13	conditions	42
pump switch	7	environmental conditions	42
Motor rating	II	Storage period	42
Motor speed	II	Symbols	ix
O		<hr/>	
<hr/>		T	
Oil		Tank volume	I
draining	24	Technical data	I
replenishing	20	Temperature ranges	II
Oil level		Transport	42
check	15, 33	Troubleshooting	30
Oil temperature	5, II	Type	I
Operating conditions	5, II	U	
Operation	19	<hr/>	
Operator		Use	5
Occupation	2	V	
Personal protection equipment (PPE)	3	<hr/>	
Qualification	1	Validity	1
Qualification level	2	Visual inspection	33
Requirement	1	Visual inspection and condition check	33
Operator control and display elements	10	W	
P		<hr/>	
<hr/>		Waste code numbers	45
Peak pressure	I	Weight	I
Pictograms	ix	<hr/>	
Pressure gauge condition check	33	R	
R		<hr/>	
<hr/>		Rating plate	9
Rechargeable battery	13	Rechargeable battery	13
Capacity	II	Capacity	II